

TIPS & TRICKS



CP.B24 ANZ LOGIC CONTROL BULL LOGIC CONTROL

The CP.B24 ANZ is a control board adapted for Australian and New Zealand markets that allows the low voltage power supply to be relocated outside of the motor enclosure.

- **TIP** – Video online with overview and programming - <http://www.automaticsolutions.com.au/assets/videos/bull/bull.html>
- **TIP** – The manual suggests that the first thing you do after mechanical installation and cable connections is run “Autoset” which is the self-learning program. It is more convenient to make the following two adjustments first (if required) and then run “Autoset”.
- **TIP** – In the “LOGICS” menu set your gate direction On or Off (see Fig4 in the manual) before performing Autoset self-learning.
- **TIP** – In the “LOGICS” menu set your automatic closing On or Off (on by default) before performing Autoset self-learning.
- **TIP** – If you do relocate the power supply be aware of voltage drop and if unsure ask your local branch for advice. Use low voltage cable only for all cable runs. This cable can be purchased from Automatic Solutions or motoring stores also stock this. 5mm cable is required for this.

CP.B24 ANZ

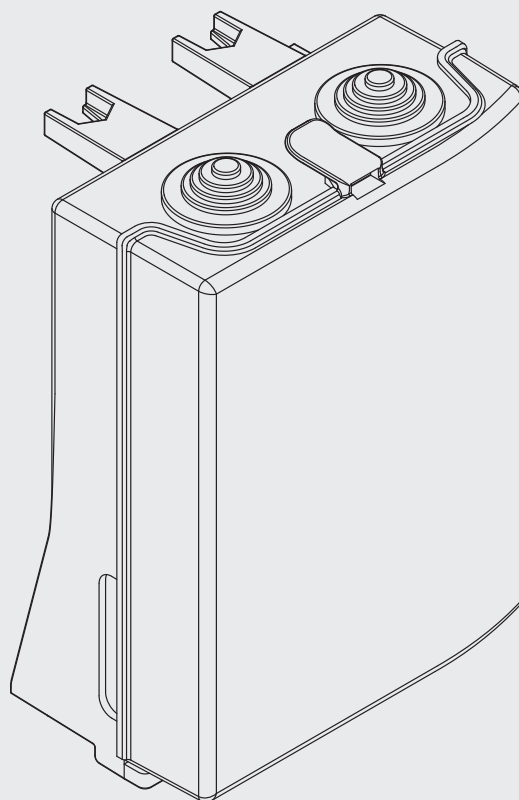

BENINCA[®]
TECHNOLOGY TO OPEN



1

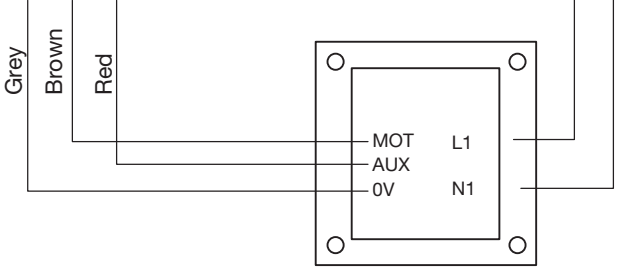
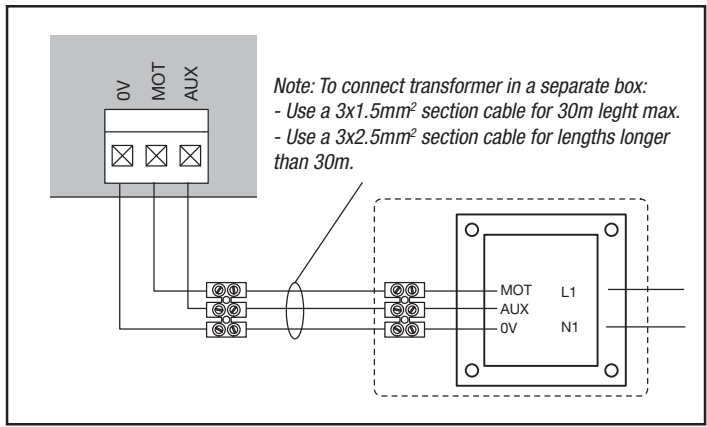
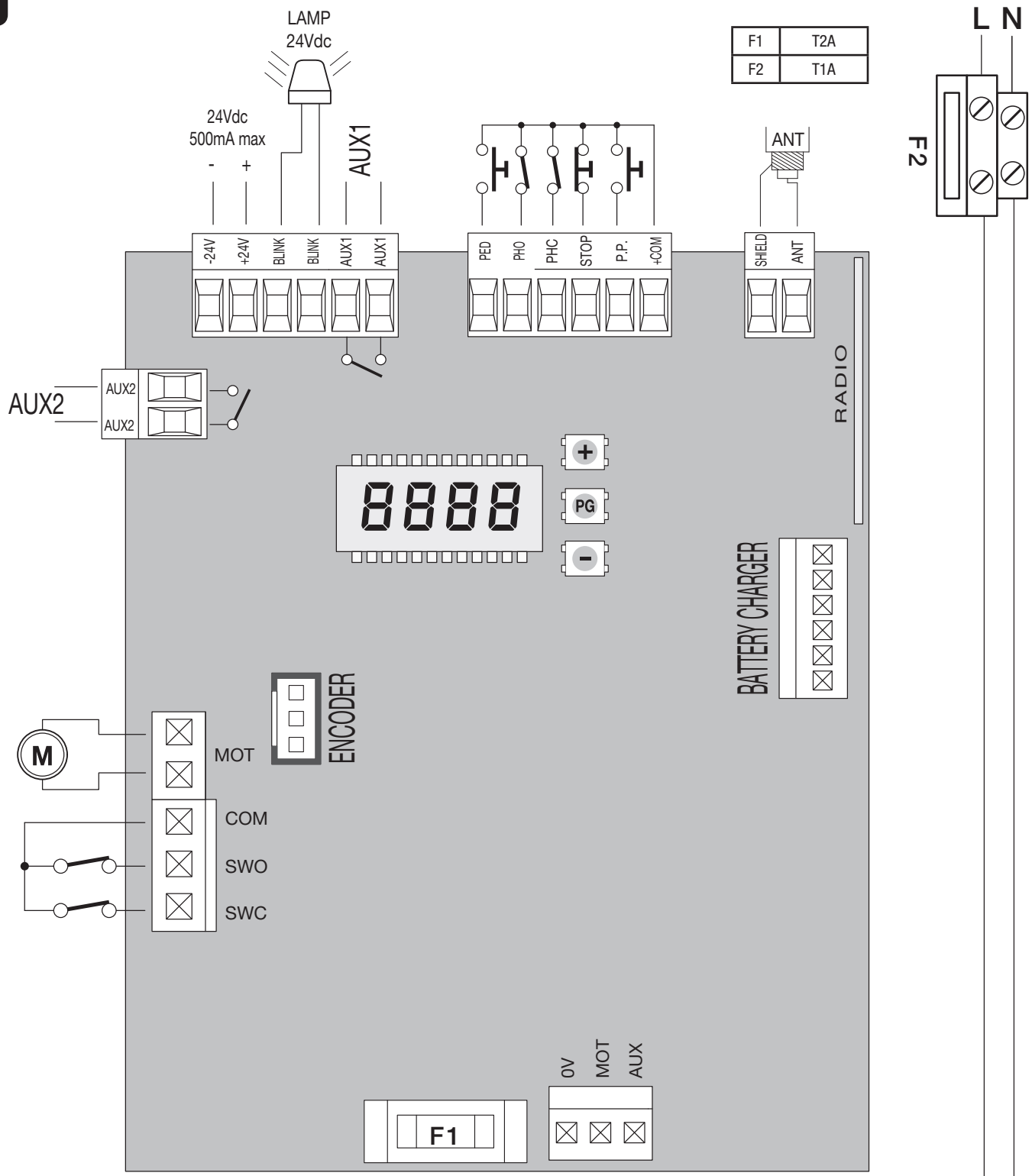

2

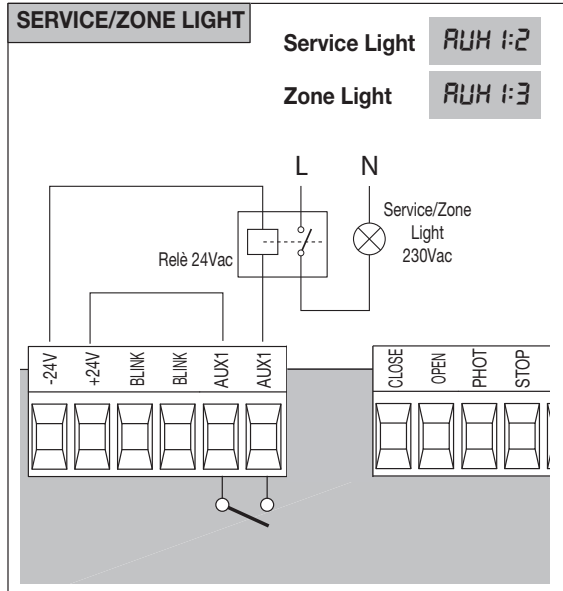
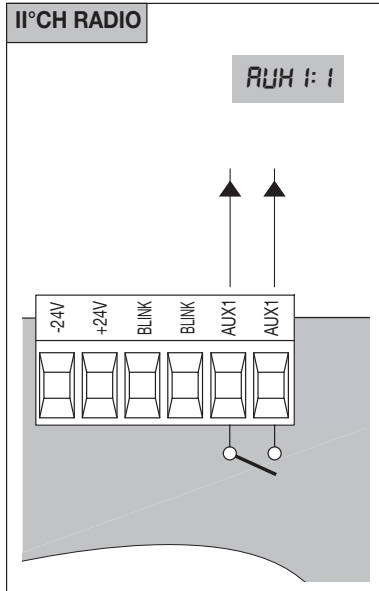
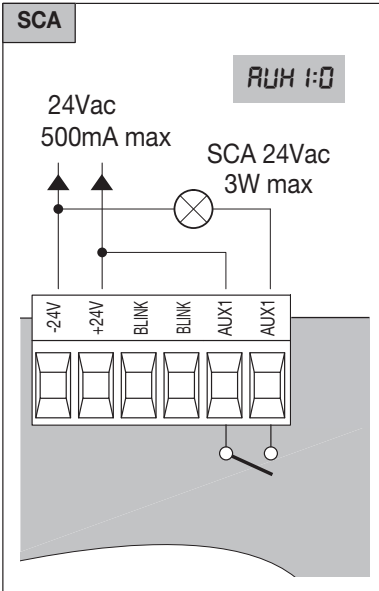

3

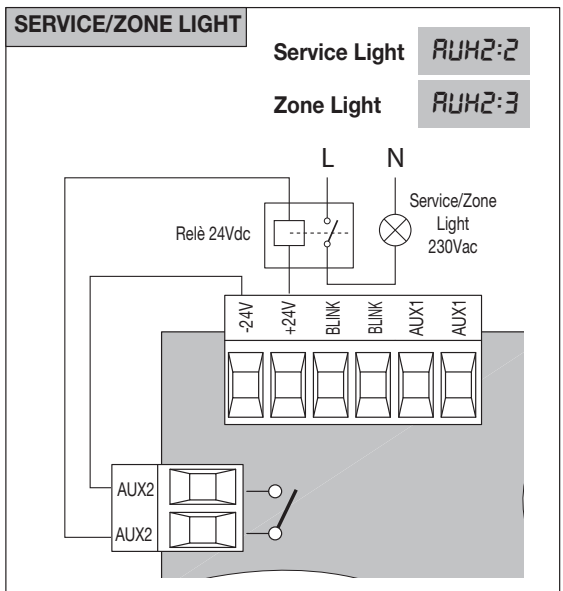
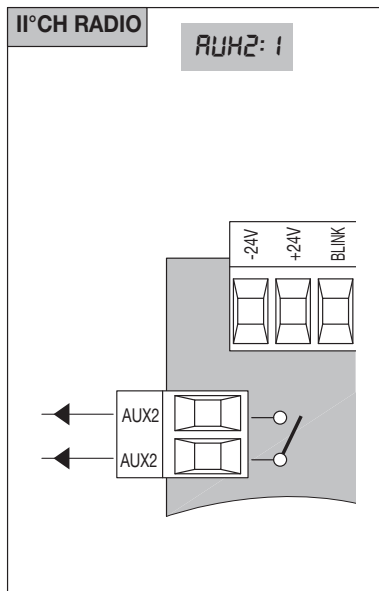
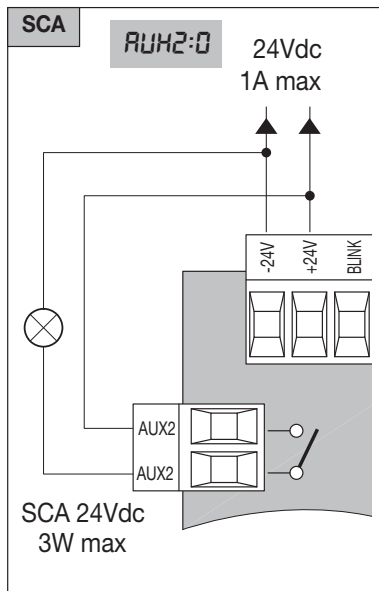

4

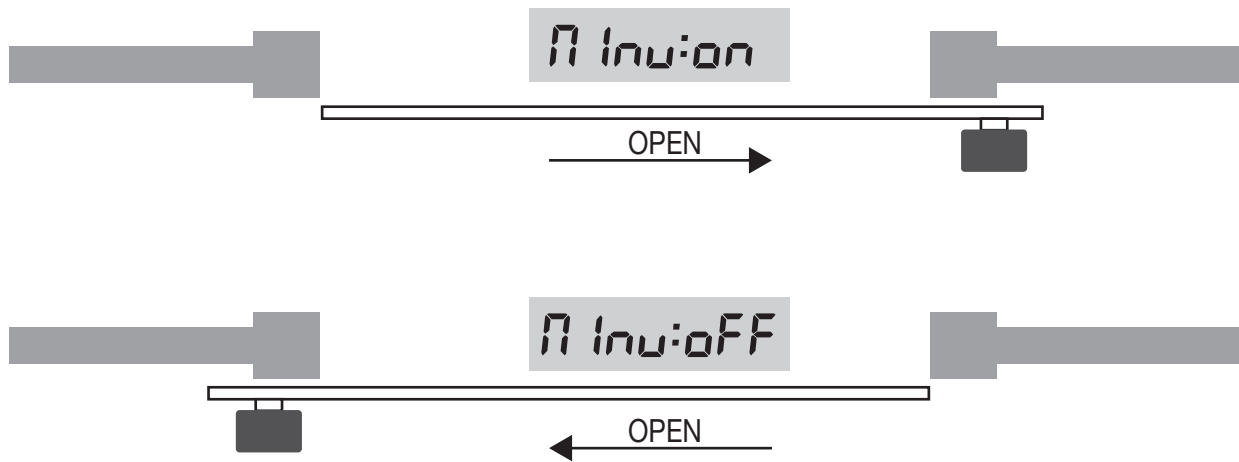

**GENERAL INFORMATIONS**

The product shall not be used for purposes or in ways other than those for which the product is intended for and as described in this manual. Incorrect uses can damage the product and cause injuries and damages. The company shall not be deemed responsible for the non-compliance with a good manufacture technique of gates as well as for any deformation, which might occur during use. Keep this manual for further use.

**INSTALLER GUIDE**

This manual has been especially written to be use by qualified fitters.

Installation must be carried out by qualified personnel (professional installer, according to EN 12635), in compliance with Good Practice and current code.

Make sure that the structure of the gate is suitable for automation.

The installer must supply all information on the automatic, manual and emergency operation of the automatic system and supply the end user with instructions for use.

**GENERAL WARNINGS**

Packaging must be kept out of reach of children, as it can be hazardous.

For disposal, packaging must be divided the various types of waste (e.g. carton board, polystyrene) in compliance with regulations in force. Do not allow children to play with the fixed control devices of the product.

Keep the remote controls out of reach of children.

This product is not to be used by persons (including children) with reduced physical, sensory or mental capacity, or who are unfamiliar with such equipment, unless under the supervision of or following training by persons responsible for their safety.

Apply all safety devices (photocells, safety edges, etc.) required to keep the area free of impact, crushing, dragging and shearing hazard.

Bear in mind the standards and directives in force, Good Practice criteria, intended use, the installation environment, the operating logic of the system and forces generated by the automated system.

Installation must be carried out using safety devices and controls that meet standards EN 12978 and EN 12453.

Only use original accessories and spare parts, use of non-original spare parts will cause the warranty planned to cover the products to become null and void.

All the mechanical and electrical parts composing automation must meet the requirements of the standards in force and outlined by CE marking.

**ELECTRICAL SAFETY**

An omnipolar switch/section switch with remote contact opening equal to, or higher than 3mm must be provided on the power supply mains.

Make sure that before wiring an adequate differential switch and an overcurrent protection is provided.

Pursuant to safety regulations in force, some types of installation require that the gate connection be earthed.

During installation, maintenance and repair, cut off power supply before accessing to live parts.

Also disconnect buffer batteries, if any are connected.

The electrical installation and the operating logic must comply with the regulations in force.

The leads fed with different voltages must be physically separate, or they must be suitably insulated with additional insulation of at least 1 mm.

The leads must be secured with an additional fixture near the terminals.

During installation, maintenance and repair, interrupt the power supply before opening the lid to access the electrical parts

Check all the connections again before switching on the power.

The unused N.C. inputs must be bridged.

**WASTE DISPOSAL**

As indicated by the symbol shown, it is forbidden to dispose this product as normal urban waste as some parts might be harmful for environment and human health, if they are disposed of incorrectly.

Therefore, the device should be disposed in special collection platforms or given back to the reseller if a new and similar device is purchased.

An incorrect disposal of the device will result in fines applied to the user, as provided for by regulations in force.

Descriptions and figures in this manual are not binding.

While leaving the essential characteristics of the product unchanged, the manufacturer reserves the right to modify the same under the technical, design or commercial point of view without necessarily update this manual.

TECHNICAL DATA

Contol unit power supply	24 Vdc
Power supply	230 Vac 50/60 Hz
Output	1 motor 24Vdc
Maximum current:	2.8 A
Accessories power supply	24Vdc 500mA max.
Protection level	IP30
Operating temp.	-20°C / +50°C
Radio receiver	built in 433,92 MHz configurabile (rolling-code or programmable + rolling-code+ ARC Advanced Rolling Code)
Memory capacity	64 rolling-code transmitters

CONTROL PANEL CP.B24 ANZ

WIRE DIAGRAM

Wire connections shown in Fig. 1 are described hereunder:

Terminals	Function	Description
L/N	Power supply	Input, 230VAC 50/60 Hz (L-Phase/N-Neutral)
L1/N1	Primary Transformer	Connector for the connection of the primary transformer L1: Line N1: Neutral
0V/MOT/AUX	Secondary Transformer	Connector for the connection of the secondary transformer 0V: 0V Input - MOT:23 VAC - AUX:18 VAC
MOT	Motor	Fast connector for motor connection
ENC	Encoder	Fast connector for encoder connection
COM SWO SWC	Limit Switches	Rapid connector for the connection of limit switches. COM:Common for limit switches SWO:Input, OPEN limit switch (N.C. contact) SWC:Input, CLOSE limit switch (N.C. contact)
PED	PEDESTRIAN	Pedestrian push-button input (N.O. contact). The gate partial opening is controlled according to the value preset by the TPED parameter. It is activated only with totally closed gate. With OPCL:ON or HTR:ON, it becomes "CLOSE" input.
PHO	Open Photocell	Input, photocell activated in both opening and closing phases
PHC	Photocell	Input, photocell is activated in the closing phase.
STOP	STOP	STOP button input (N.C. contact)
P.P.	Step by step	Input, Step-by-Step push-button (Normally Open contact) If the logics is OPCL=ON or HTR=ON, the OPEN input function is provided. If the logics HTR is ON, it is FORBIDDEN to use the input with timers or other similar systems.
+COM	COMMON	Common for all control inputs.
SHIELD/ANT	antenna	Connection antenna to the built-in receiver SHIELD: Screen / ANT: Signal
+ 24V -	24 Vdcs	Accessories power supply 24Vdc/500mA max.
BLINK	Flashing	Connection to flashing light 24Vdc 15W max.
AUX1	AUX1	Normally open (N.O.), clean contact, which is configurable like SCA (open gate indicator light) through parameter AUX1, second radio channel, courtesy or area light (see Parameter AUX 1).
AUX2	AUX2	Normally open (N.O.), clean contact, which is configurable like SCA (open gate indicator light) through parameter AUX2, second radio channel, courtesy or area light (see Parameter AUX 2).

RUN SELF-LEARNING AND ANTI-CRUSHING DEVICE SETTING

After carrying out the wire connections of the automatic system and programming all functions required, it is **MANDATORY** to carry out the self-learning of dimensions and the calibration of intervention thresholds of the anti-crash device (amperometrics).

Access the AUTO menu and press the <PG> push-button.

The wording PUSH is displayed.

Press the push-button <PG> again and self-calibration will start: the wording PRG is displayed while at least 2 complete operations are carried out.

At the end of procedure, OK will be displayed.

The procedure can be carried out from any position of the gate leaf and can be interrupted at any moment by pressing the <+> and <-> keys at the same moment, or with the triggering of STOP/PHO/PHC/DAS/OPEN/CLOSE inputs.

At the end of self-setting, the PMO and PMC parameters, if previously modified, are shown as default values. If the procedure is not successful, the wording ERR appears. Check that no obstacles or frictions are present.

*CAUTION!:

The torque value also includes changes in the resistance of the door during movement.

The entire stroke is divided in 64 opening points and 64 closing points where the optimal operating torque is read and memorised by the control unit. The PMO and PMC parameters are an offset figure with respect to calculations made by the control unit.

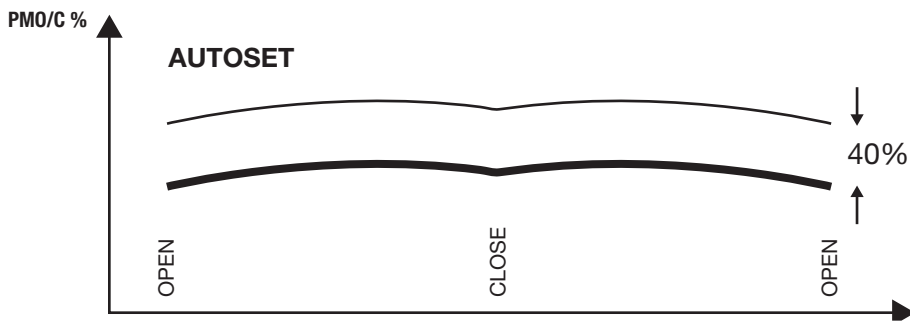

The default value at 40% is normally enough to avoid false interventions. In any case, if PMO and PMC should be modified, the impact tests set out by regulations in force will have to be carried out.

PROGRAMMING

The programming of the various functions of the control unit is carried out using the LCD display on the control unit and setting the desired values in the programming menus described below.

The parameters menu allows you to assign a numerical value to a function, in the same way as a regulating trimmer.

The logic menu allows you to activate or deactivate a function, in the same way as setting a dip-switch.

Other special functions follow the parameters and logic menus and may vary depending on the type of control unit or the software release.

USE OF PROGRAMMING KEYS

Press <PG> key to gain access to the Main Menu (PAR>>LOG>>RADIO>>...). These keys can be selected by pressing + and - keys.

Select the Main menu with <PG> key to enter the desired Function Menu .

- If <+> is pressed, the Function Menu can be scrolled from top to bottom.
- If <-> is pressed, the Function Menu can be scrolled from bottom to top.
- If <PG> key is pressed, presetting to be modified can be entered.
- The preset values can be modified by using <+> and <-> keys.
- The value is programmed if <PG> key is pressed again. The word "PRG" appears on the display.

NOTES:

Simultaneously pressing <+> and <-> from inside a function menu allows you to return to the previous menu without making any changes.

Hold down the <+> key or the <-> key to accelerate the increase/decrease of the values.

After waiting 30s the control unit quits programming mode and switches off the display.

Pressing <-> with the display turned off means an impulse of P.P.

PARAMETERS, LOGIC AND SPECIAL FUNCTIONS

In the charts following the single available functions are described in the plant.

PARAMETERS (PAR)			
MENU	FUNCTION	MIN-MAX-(Default)	MEMO
t_{cA}	Automatic closure time. It is enabled only with "TCA"=ON logic. At the end of the preset time, the control unit controls a closure operation.	1-240-(40s)	
t_{PEd}	The stroke time of the gate leaf is adjusted during the partial opening phase controlled by the pedestrian input.	5-100-(20%)	
t_{SN}	Braking is adjusted. The value is expressed in percentage on the aggregate value of the stroke.	0-100-(20%)	
$FStS$	The opening and closing speed is adjusted.	20-99-(70)	
$SLdS$	Speed during braking is adjusted.	20-99-(50)	
Pn_o	Adjustment of amperometric sensor sensitivity in opening* 1: maximum sensibility - 99**: minimum sensibility	1-99-(40%)	
Pn_c	Adjustment of amperometric sensor sensitivity in closing* 1: maximum sensibility - 99**: minim sensibility	1-99-(40%)	
t_{LS}	It is activated only with AUX1 or AUX2 parameter preset on value 2. The activation time of the service light is adjusted.	1-240-(60s)	

AUX 1	It selects the operating mode of the AUX 1 output: 0: Open gate indicator light. The light is off when the door is closed, flashes with moving door and is on with open door. See wire diagram. 1: Second radio channel. The output is controlled by the radio channel of the built-in receiver (see RADIO Menu). 2: Service light. The contact closes for the time preset with TLS parameter. The countdown starts at the inception of operation. 3: Area light. The contact closes in the opening phase and remains closed for the entire TCA time. It opens only with closed door. See wire diagram, Fig. 2.	0-3-(0)	
AUX 2	The same operating options as AUX1 output, but referred to AUX2 terminals. See connections in Fig. 3.	0-3-(1)	
tbr	Stop space is adjusted after reaching the opening and closing limit switch.	1-3-(3)	
SP in	It regulates the reversal space that the leaf runs as consequence a result of the safety edge action (or triggering of the amperometric sensor). During the reversal phase any further action of safety edge or photocells is ignored. This value is expressed in second.	1-4 (2)	

*** ATTENTION: A wrong formulation of these parameters can be dangerous.**

Respect the regulations in force!

** By presetting the value at 99 before carrying out the Autotest, the control unit does perform the calculation of the torque, as indicated in paragraph "LEARNING OF VALUES", and the amperometric sensor is disabled.

LOGICS (LoG I)			
MENU	FUNCTION	DEAFULT	MEMO
tca	Enables or disables automatic closing On: automatic closing enabled Off: automatic closing disabled	(ON)	
ibl	Enables or disables multi-flat function. On: multi-flat function enabled. The step-by-step and pedestrian commands have no effect during the opening phase. Off: multi-flat function disabled.	(OFF)	
ibca	During the TCA phase, the PP controls are enabled or disabled. On: PP controls are disabled. Off: PP controls are enabled.	(OFF)	
scl	The rapid closure is enabled or disabled. It can be activated only if TCA:ON On: enabled rapid closure. With open gate, the photocell activation causes the automatic closure after 3 s. If the photocell is activated during the opening phase, the operation is completed and closure starts after 3s Off: disabled rapid closure.	(OFF)	
pp	The operating mode of "P.P. Push button" and of the transmitter are selected. On: Operation : OPEN > CLOSE > OPEN > Off: Operation: OPEN > STOP > CLOSE > STOP >	(OFF)	
pre	Forewarning flashing light enabled or disabled. On: enabled forewarning flashing light. The flashing light is activated 3 s before the starting of the motor. Off: disabled forewarning flashing light.	(OFF)	
htr	The Service Man function is enabled or disabled. (The OPCL logics is automatically enabled). On: Service Man operation. The Step-by-Step input becomes OPEN input, the PED input becomes CLOSE input. If the OPEN and CLOSE keys are pressed at the same time, the system will STOP. The OPEN/CLOSE push buttons should be kept pressed for the entire operating time. Off: Automatic operation.	(OFF)	
ltca	During the TCA time, the blinker is enabled or disabled. On: Enables blinker. Off: Disables blinker.	(OFF)	

cuAr	The code programmable transmitters is enabled or disabled. On: Radio receiver enabled only for rolling-code transmitters. Off: Receiver enabled for rolling-code and programmable code transmitters (self-learning and Dip Switch).	(OFF)	
SoFt	Soft start is enabled or disabled. On: Starting is performed at reduced speed and then movement is restored to normal speed. Off: Soft start is disabled.	(ON)	
oPcL	PP input as OPEN and PED input as CLOSED are enabled or disabled. On: PP input is enabled as OPEN and PED input is enabled as CLOSED. Off: PP and PED inputs are enabled with their function.	(OFF)	
n lnu	Select the opening direction of the motor (see Fig. 4): On: Right side motor mount Off: Left side motor mount If this logics is modified, this SELFTESTING will have to be repeated.	(OFF)	
rEN	The remote storage of the radio transmitter codes is enabled or disabled (see par. REMOTE LEARNING). On: Enabled remote storage Off: Disabled remote storage.	(ON)	
tStn	The motor checks are enabled or disabled. On: Checks are enabled. If the checks are not successful, the door/gate will not move. Off: Disabled check.	(ON)	
Enc	The Encoder is enabled or disabled. On: the encoder is enabled. Off: the encoder is disabled. Timed operation, self-learning and self-setting are not available. If this logics is activated after being disabled, a new SELFTEST should be carried out.	(ON)	
tHrN	Enables or disables motor thermal protection intervention On: enabled Off: disabled	(ON)	

RADIO (*rRd*)

MENU	FUNCTION
PP	By selecting this function, the receiver is waiting for (Push) a transmitter code to be assigned to the step-by-step function. Press the transmitter key, which is to be assigned to this function. If the code is valid, it will be stored in memory and OK will be displayed. If the code is not valid, the Err message will be displayed.
2ch	By selecting this function, the receiver is waiting for (Push) a transmitter code to be assigned to the second radio channel. Press the transmitter key, which is to be assigned to this function. If the code is valid, it will be stored in memory and OK will be displayed. If the code is not valid, the Err message will be displayed.
PEd	When this function is selected, the receiver awaits (Push) a transmitter code to be assigned to the PED function. Press the transmitter key, which is to be assigned to this function. If the code is valid, it will be stored in memory and OK will be displayed. If the code is not valid, the Err message will be displayed.
clr	By selecting this function, the receiver is waiting for (Push) a transmitter code to be erased from memory. If the code is valid, it will be stored in memory and OK will be displayed. If the code is not valid, the Err message will be displayed.
rEr	The memory of the receiver is entirely erased. Confirmation for the operation is asked.

Note: Transmitters ARC and Rolling-code/Fixed code cannot be stored in memory at the same time. For example, if the first transmitter stored in memory is ARC, the following transmitters could be only ARC. Use the RTC function to completely erase the memory should the type of transmitters be changed.

NUMBER OF CYCLES (*nRn*)

The number of cycles (open+close) completed by the system is displayed.
When the push-button <PG> is pressed once, the first 4 digits are displayed, if the push-button is pressed once more, the last 4 digits are displayed.
E.g. <PG> 0012 >>> <PG> 3456: 123.456 cycles were performed.

MAINTENANCE (MRC I)

This function allows to activate the indication of maintenance required after a certain number of operations, preset by the installer. To activate and select the number of operations, proceed as follows:
Press the <PG> button, OFF is displayed, indicating that the function is disabled (default).
Select one of the numbers shown (from OFF to 100) by using the <+> and <-> keys . The figures express the value of hundreds of cycles (e.g.: the number 50 means 5000 operations).
Press OK to activate the function. The PROG message is displayed.
When the flashing light flashes for around 10 sec at end of operation, this means that maintenance operations are needed.

RESET (RE5)

RESET of the control unit. WARNING: Returns the control unit to the default values.
When the <PG> push-button is pressed once, the RES wording begins to flash, if the push-button<PG> is pressed once more, the control unit is reset.
Note: neither the transmitter codes nor the position and stroked of the gate leaf will be erased from the receiver.

AUTOSET (AUT0)

The self-calibration of the triggering thresholds of the anti-crash device (amperometric sensor), as well as the stroke learning are performed. See paragraph SELF-LEARNING

PASSWORD (codE)

It allows to type in an access protection code to the programming of the control unit.
A four-character alphanumeric code can be typed in by using the numbers from 0 to 9 and the letters A-B-C-D-E-F.
The default value is 0000 (four zeros) and shows the absence of a protection code.
While typing in the code, this operation can be cancelled at any moment by pressing keys + and – simultaneously. Once the password is typed in, it is possible to act on the control unit by entering and exiting the programming mode for around 10 minutes in order to allow adjustments and tests on functions.
By replacing the 0000 code with any other code, the protection of the control unit is enabled, thus preventing the access to any other menu. If a protection code is to be typed in, proceed as follows:
- select the Code menu and press OK.
- the code 0000 is shown, also in the case a protection code has been previously typed in.
- the value of the flashing character can be changed with keys + and -.
- press OK to confirm the flashing character, then confirm the following one.
- after typing in the 4 characters, a confirmation message “CONF” appears.
- after a few seconds, the code 0000 appears again
- the previously stored protection code must be reconfirmed in order to avoid any accidental typing in.
If the code corresponds to the previous one, a confirmation message “OK” appears.
The control unit automatically exits the programming phase. To gain access to the Menus again, the stored protection code must be typed in.
IMPORTANT: TAKE NOTE of the protection code and KEEP IT IN A SAFE PLACE for future maintenance operations. To remove the code from a protected control unit, enter the programming mode with the password and reset the code to the 0000 default value.
IF YOU LOOSE THE CODE, PLEASE CONTACT THE AUTHORISED SERVICE CENTER FOR THE TOTAL RESET OF THE CONTROL UNIT.

ATTENTION:

After any LOGIC change or control panel reset, it is necessary to perform a self-learning procedure (Menu Auto - See Stroke self learning)

EMERGENCY BATTERY

An optional accessory to power the control unit is available in the event the mains power supply is cut off.
The kit is composed of a battery charger and two 12V rechargeable batteries, fixing brackets, screws and cables.
For further information, please refer to instructions supplied with the accessory.

TRANSMITTER REMOTE LEARNING

If the transmitter code is already stored in the receiver, the remote radio learning can be carried out (without accessing the control unit).
The REM logics must be ON.

IMPORTANT: The procedure should be carried out with gate in the opening phase, during the TCA dwell time.

Proceed as follows:

- 1 Press the hidden key of the transmitter, the code of which has already been stored in memory.
- 2 Within 5 seconds, press the already memorised transmitter key corresponding to the channel to be matched to the new transmitter. The flashing light switches on.
- 3 Within 10 seconds, press the hidden key of the new transmitter.
- 4 Within 5 seconds, press the key of the new transmitter to be matched to the channel selected at item 2. The flashing light switches off.
- 5 The receiver stores the new transmitter code and exits from the programming mode immediately.

ERROR MESSAGES

Some messages that are displayed in the event of malfunctions are shown hereunder:

<i>Err</i>	Error, radiotransmitter self-adjustment or self-learning	If the error occurs during self-learning, check the STOP/PHOTO/PP/CLOSE inputs or whether frictions occur during the door leaf stroke. If the error occurs during self-learning of the radio-transmitters, this means that the memory of the receiver is no longer able to receive other transmitters or the transmitter is not compatible.
<i>Err 1</i>	Error, motor	Check connections to the motor
<i>Err 2</i>	Error, photocells	Check connections to photocells
<i>Err 5</i>	Error, encoder	Check connections to the encoder
<i>RnP</i>	Triggering of the amperometric sensor	An obstacle or a point of friction has caused the triggering of the amperometric sensor. Remove the obstacle or check the door stroke. Act on the PMO/PMC parameter, if required.
<i>Ehrn</i>	Triggering of the thermal switch	The control unit has switched the system to a rest status due to an excessive number of consecutive operations. If a sufficient cooling time has elapsed, the control unit is reset to normal operation. In the negative, a fault in the motor might have occurred, which requires the replacing of the motor.

DIAGNOSTICS

In the event of malfunctions, by pressing key + or - the status of all inputs (limit switches, control and safety) can be displayed. One segment of the display is linked to each input. In the event of failure it switches on according to the following scheme.

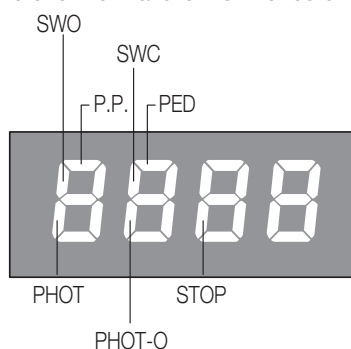

N.C. inputs are represented by the vertical segments. N.O. inputs are represented by the horizontal segments.

WASTE DISPOSAL

If the product must be dismantled, it must be disposed according to regulations in force regarding the differentiated waste disposal and the recycling of components (metals, plastics, electric cables, etc.). For this operation it is advisable to call your installer or a specialised company.

BENINCA[®]

AUTOMATISMI BENINCÀ SpA - Via Capitello, 45 - 36066 Sandrigo (VI) - Tel. 0444 751030 r.a. - Fax 0444 759728
