

TIPS & TRICKS



BULL424SW REMOTE POWER CONNECTION

The BULL424SW allows the low voltage power supply to be relocated outside of the motor enclosure.

- **TIP** – Low voltage power supply can be solar power or relocated low voltage transformer.
- **TIP** – Both options of remote power involve using the battery backup pins on the side of the board.
 - **TIP** – Connection is as per the photos below paying attention to the polarity.
 - **TIP** – If using solar power bring the 24 volts from your battery to the battery backup pins.
- **TIP** – If using solar power ensure the battery has had at least 2-3 solid days of good charge before connecting and attempting programming.
- **TIP** – If you do relocate the power supply be aware of voltage drop and if unsure ask your local branch for advice. Use low voltage cable only for all cable runs. This cable can be purchased from Automatic Solutions or motoring stores also stock this. 5mm cable is required for this.
- **TIP** – If using an AC transformer, you will need to use a bridge rectifier to convert to DC power.

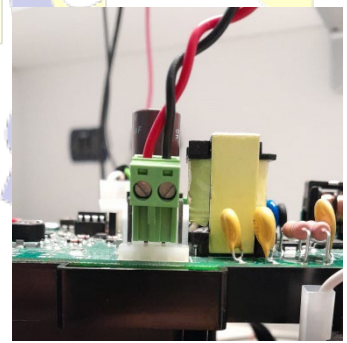
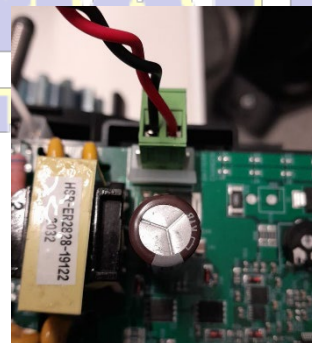
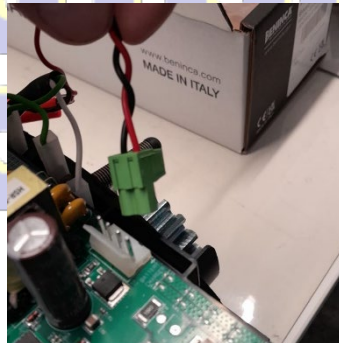
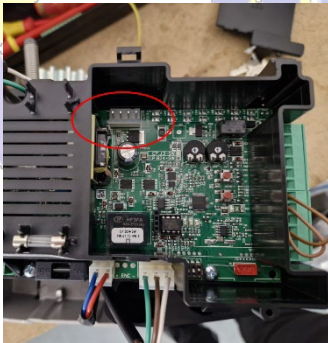

BULL424 SW

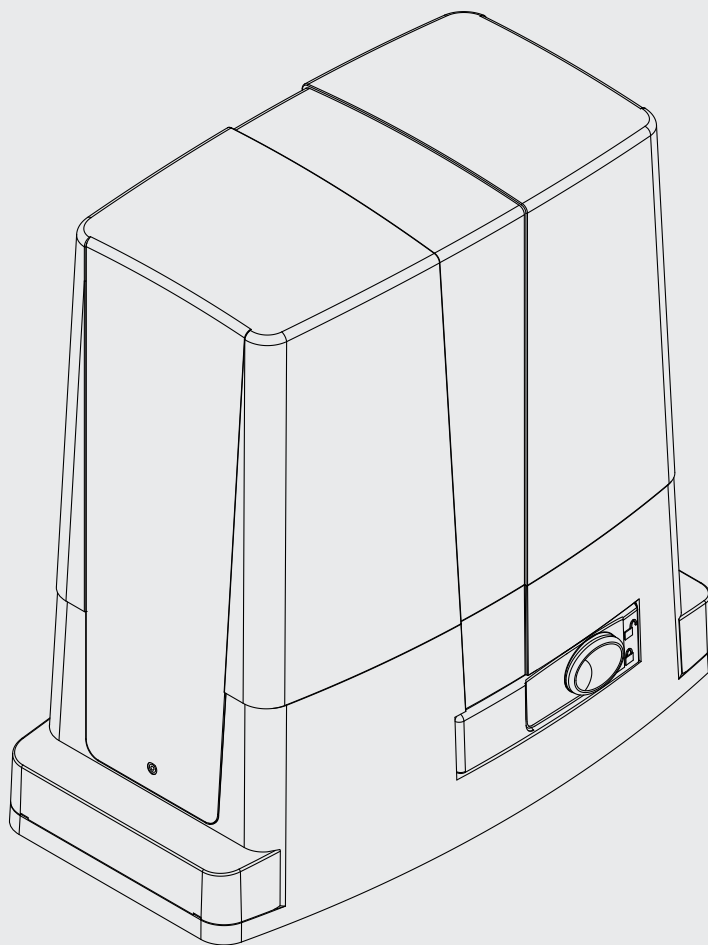

BENINCA[®]
TECHNOLOGY TO OPEN



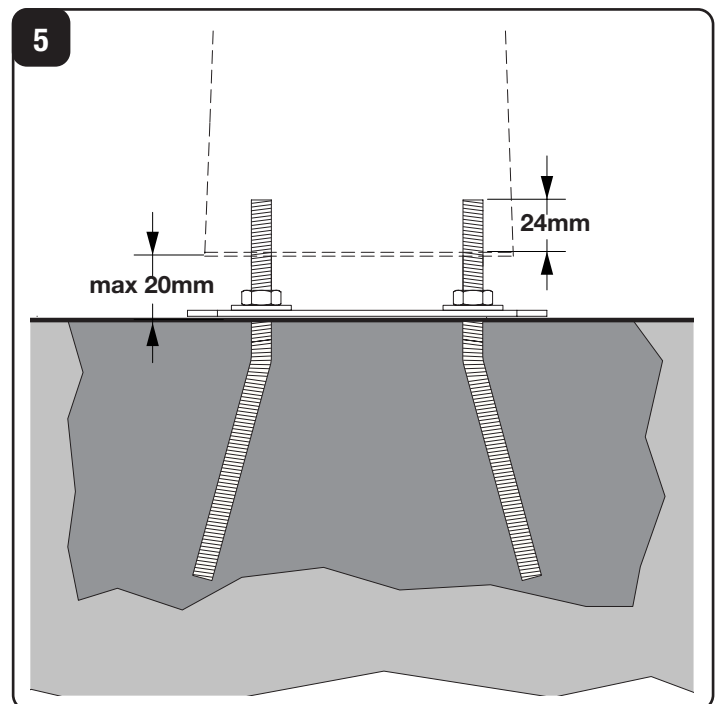
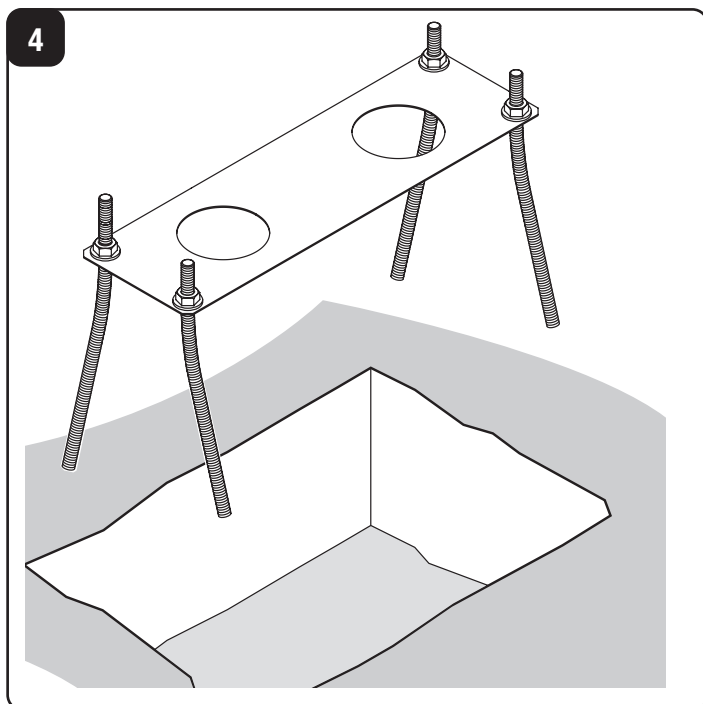
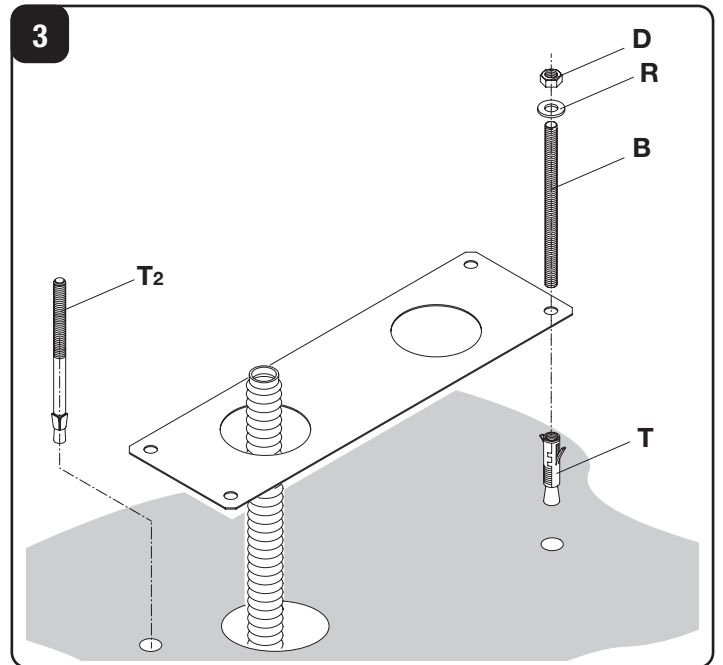
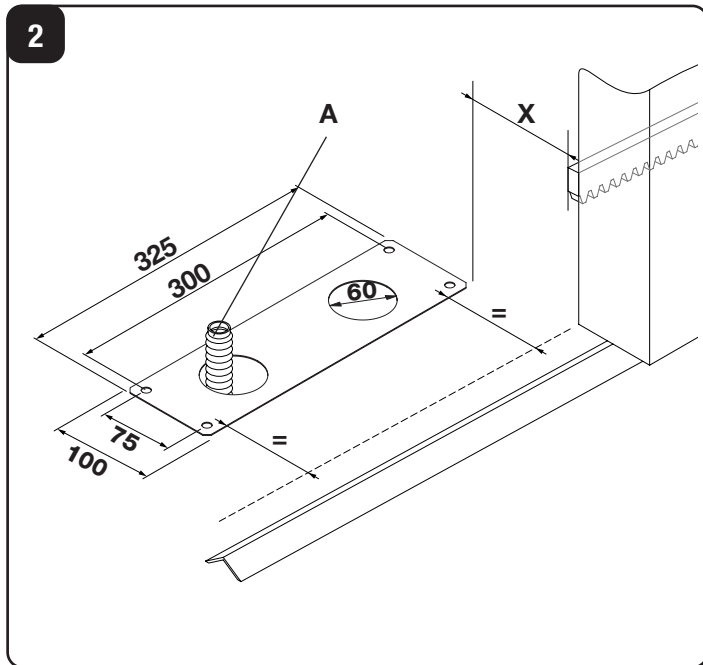
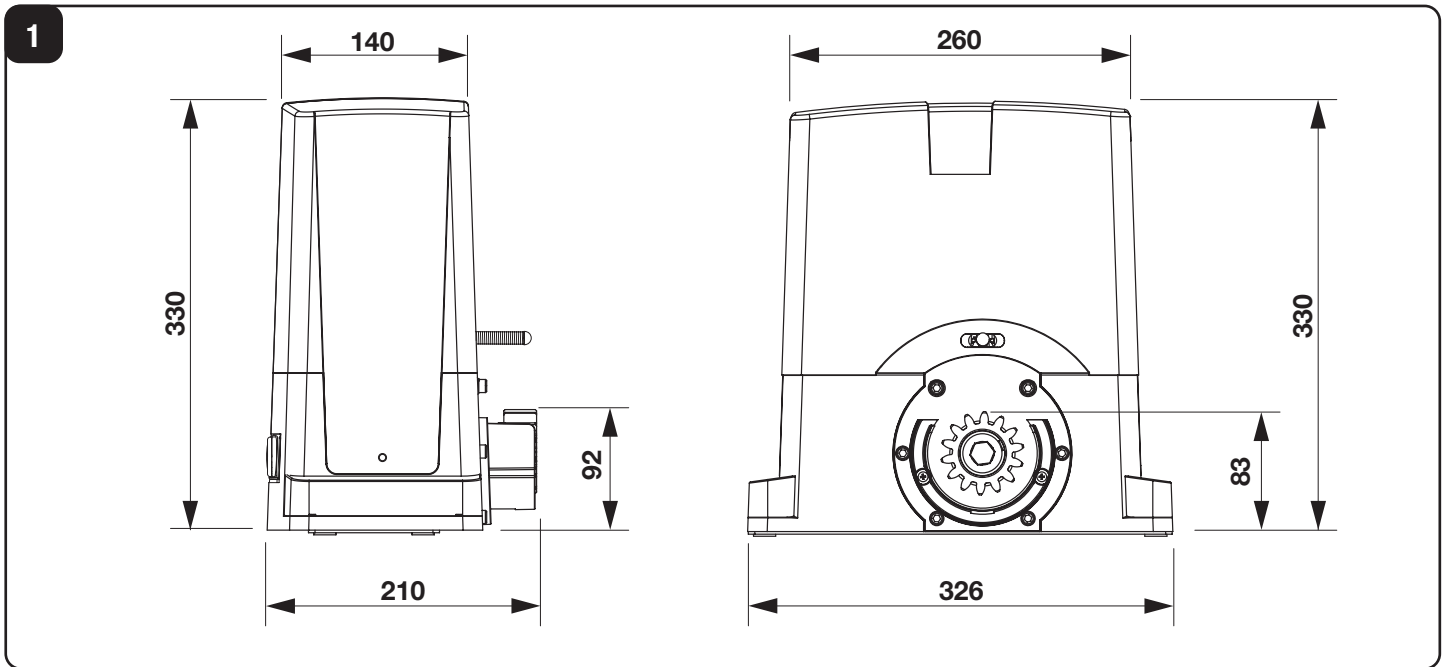

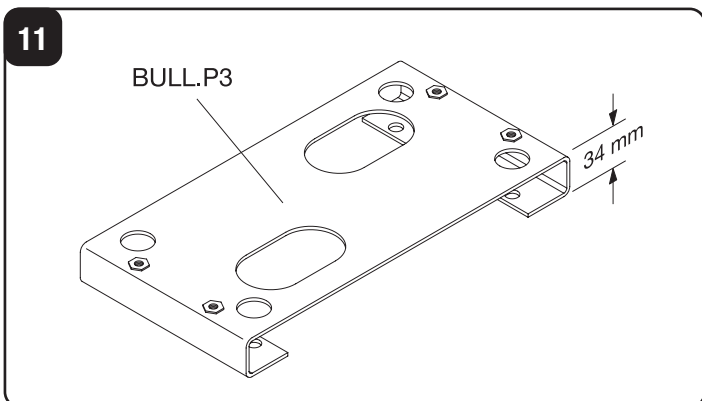
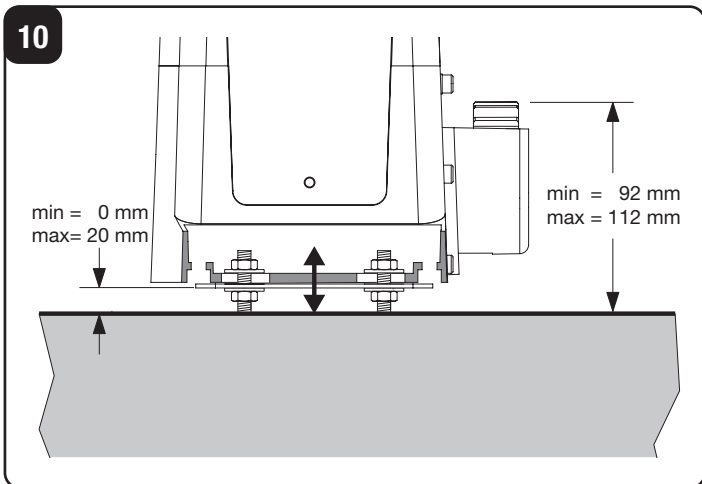
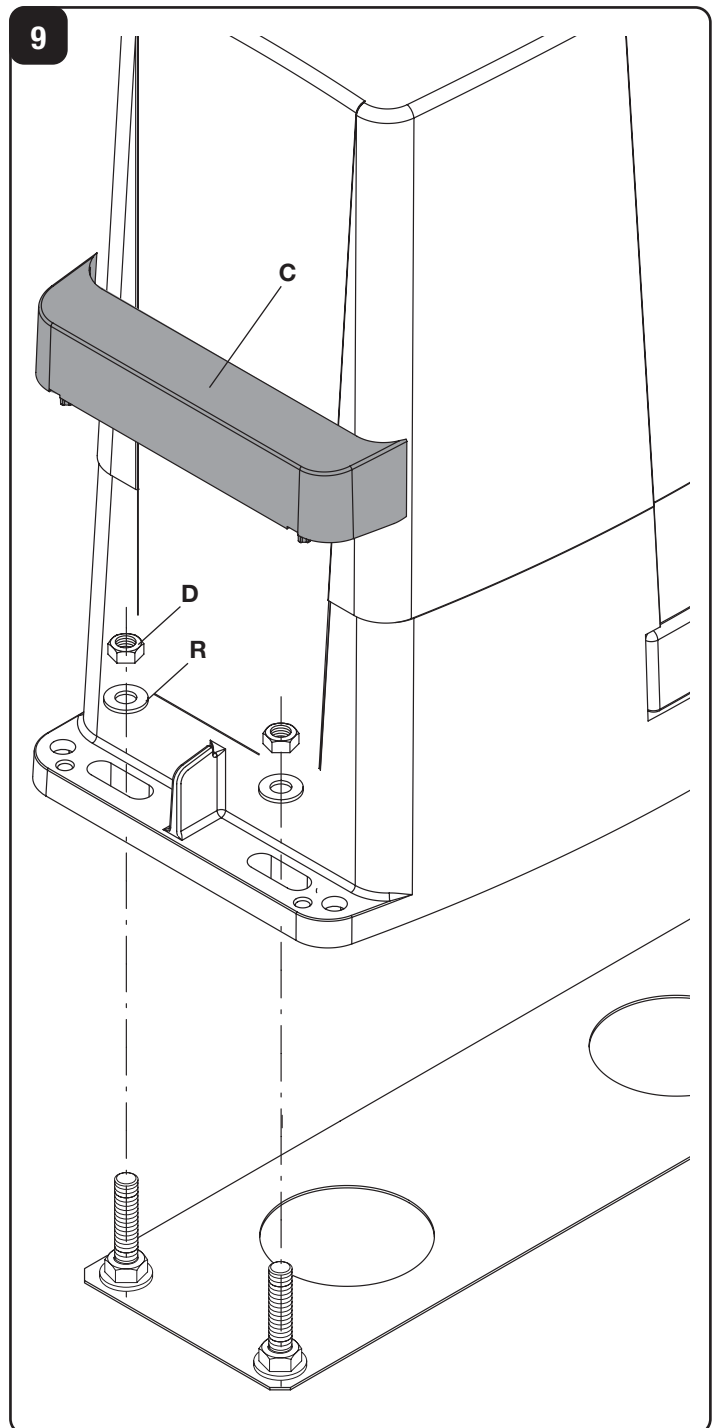
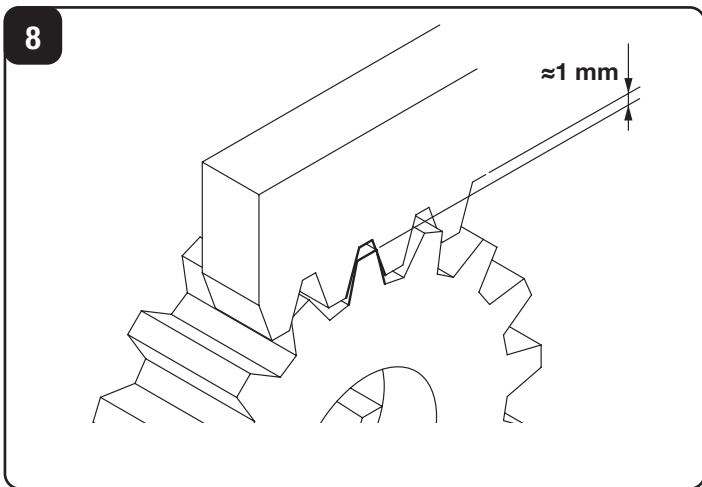
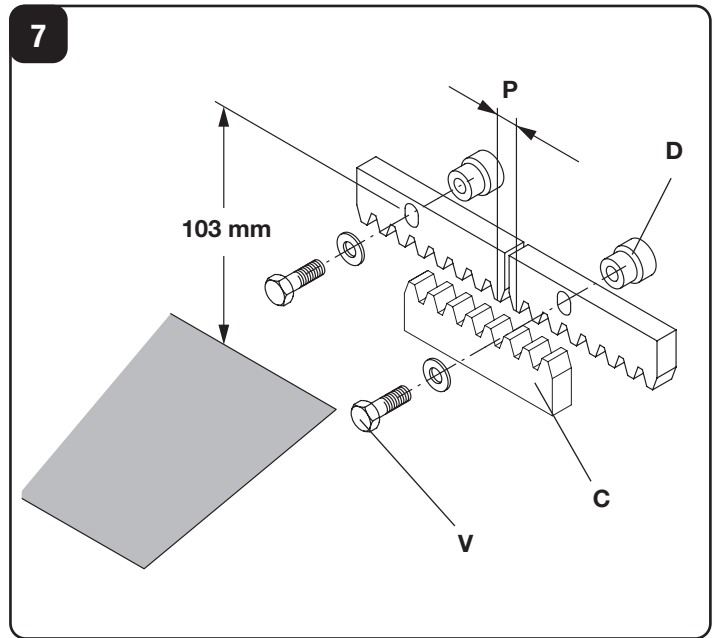
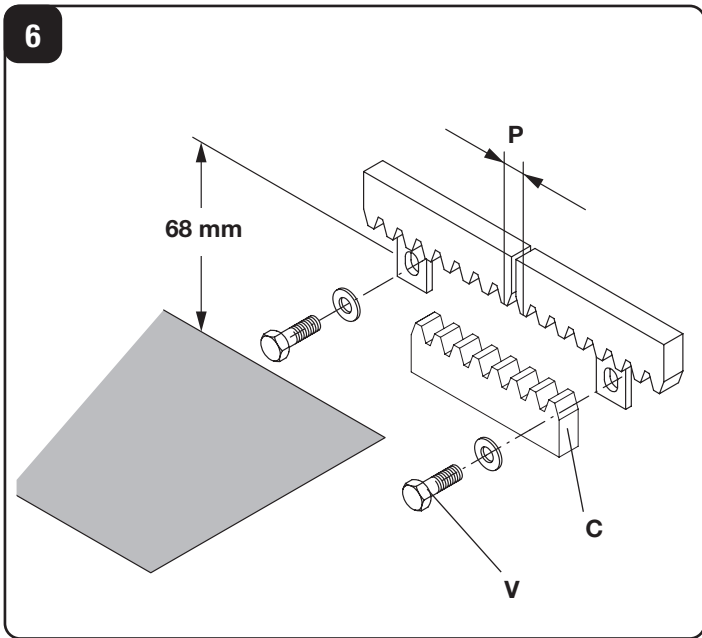

12

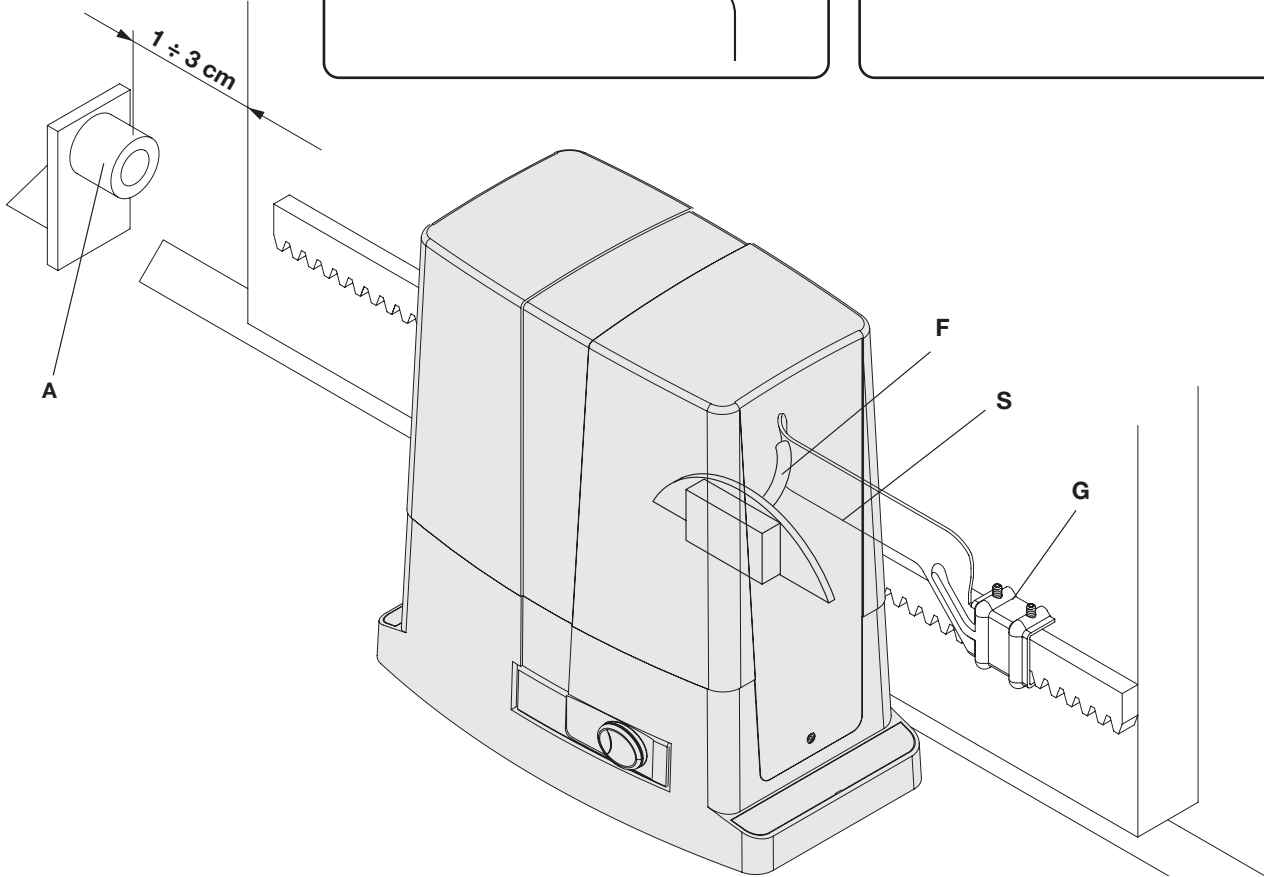
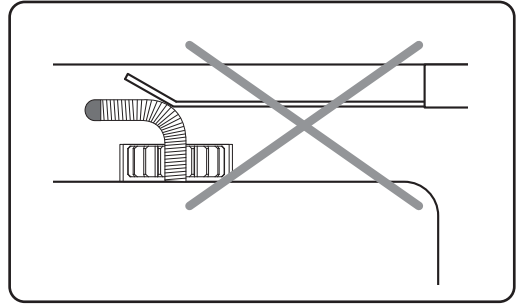
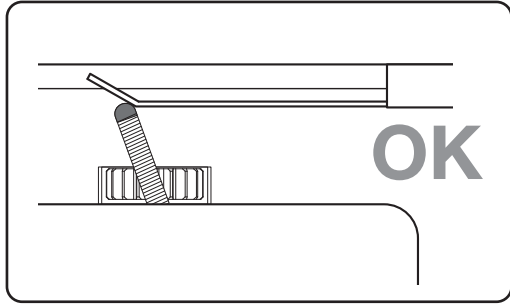

13

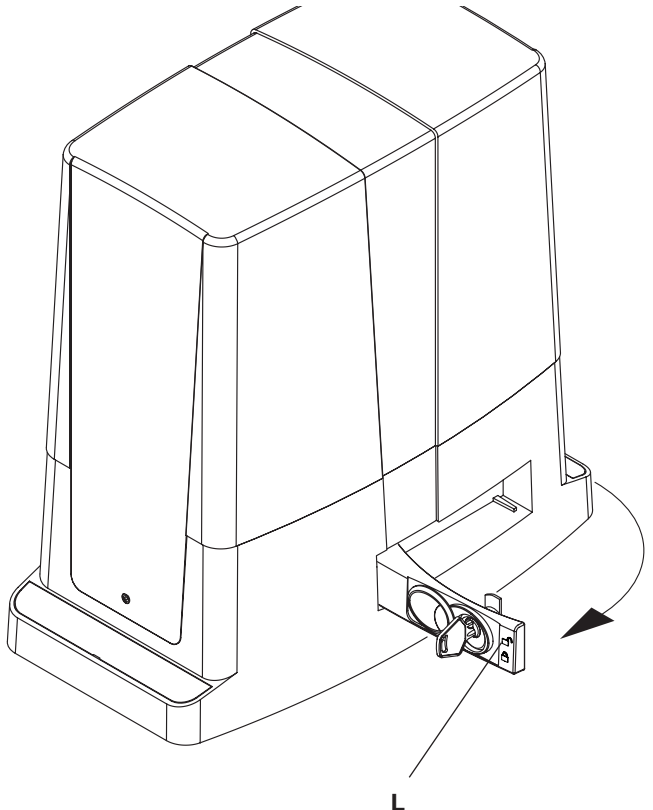
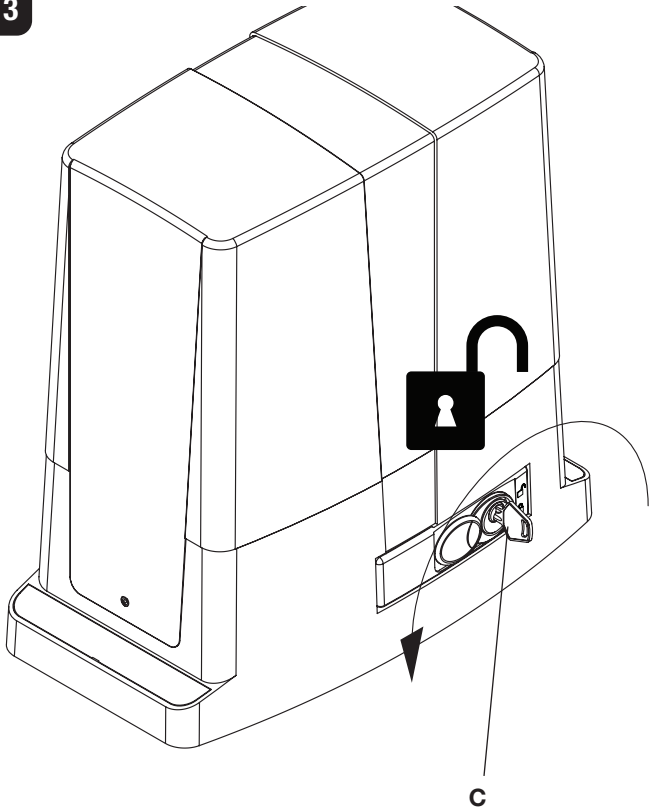

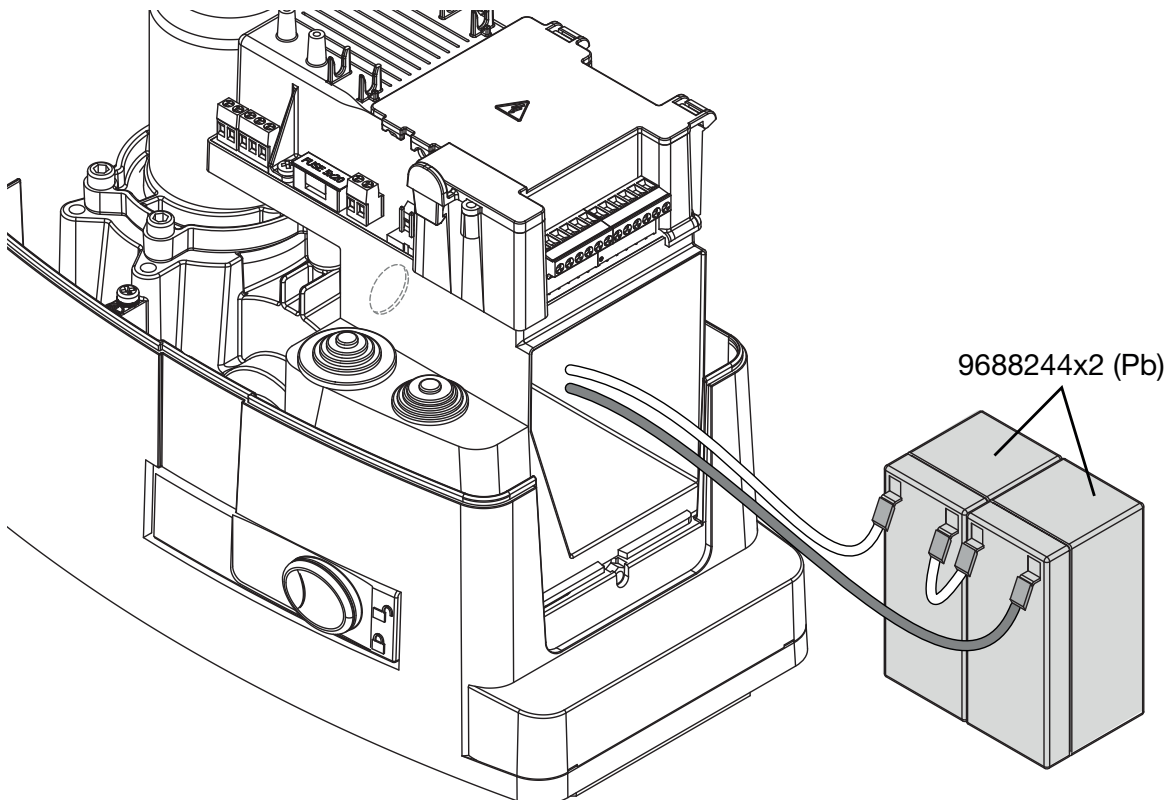
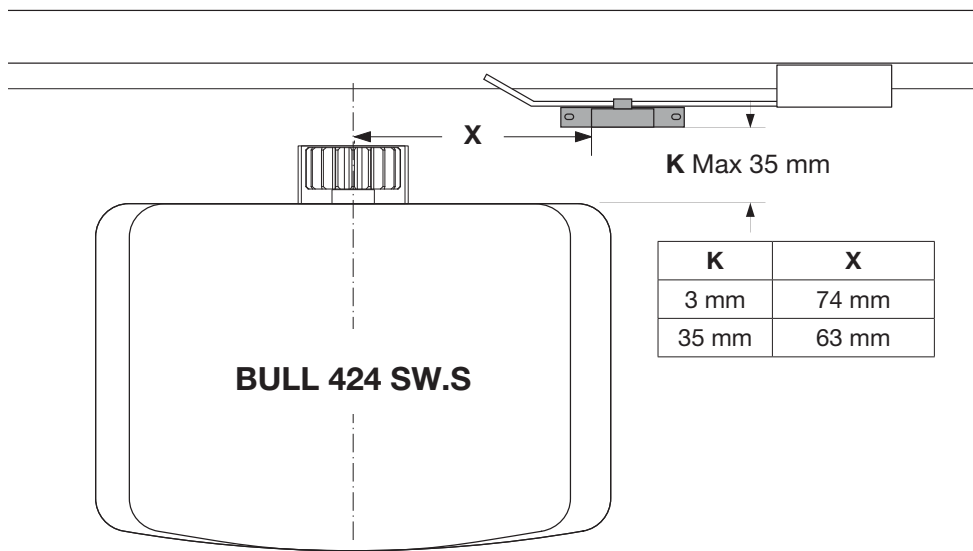
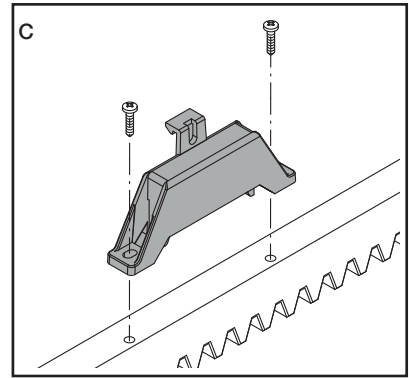
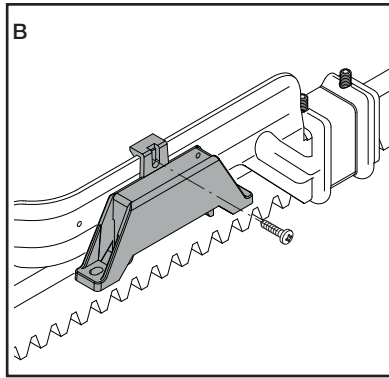
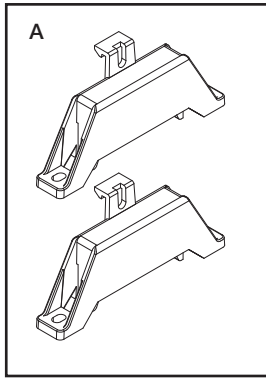

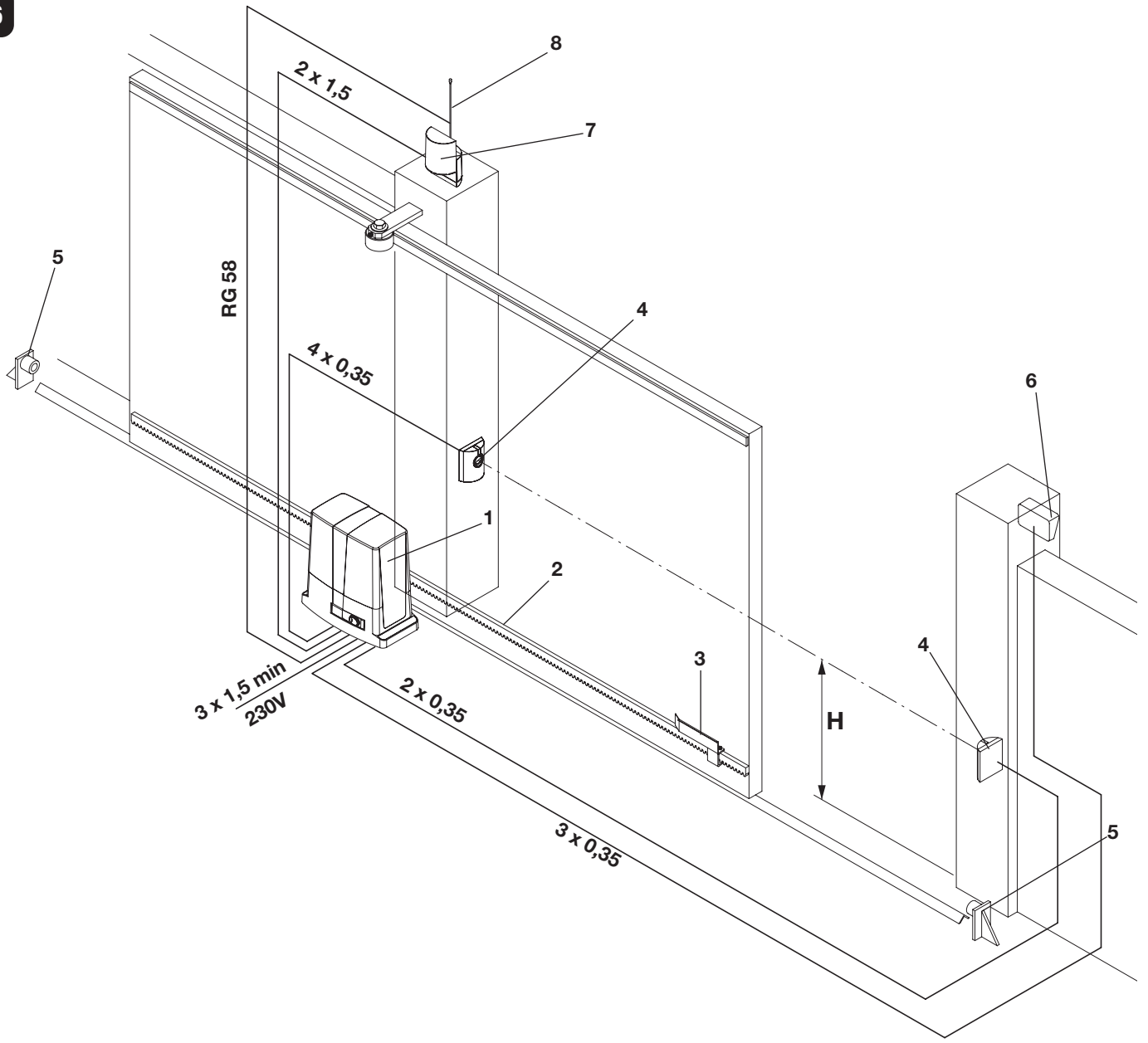

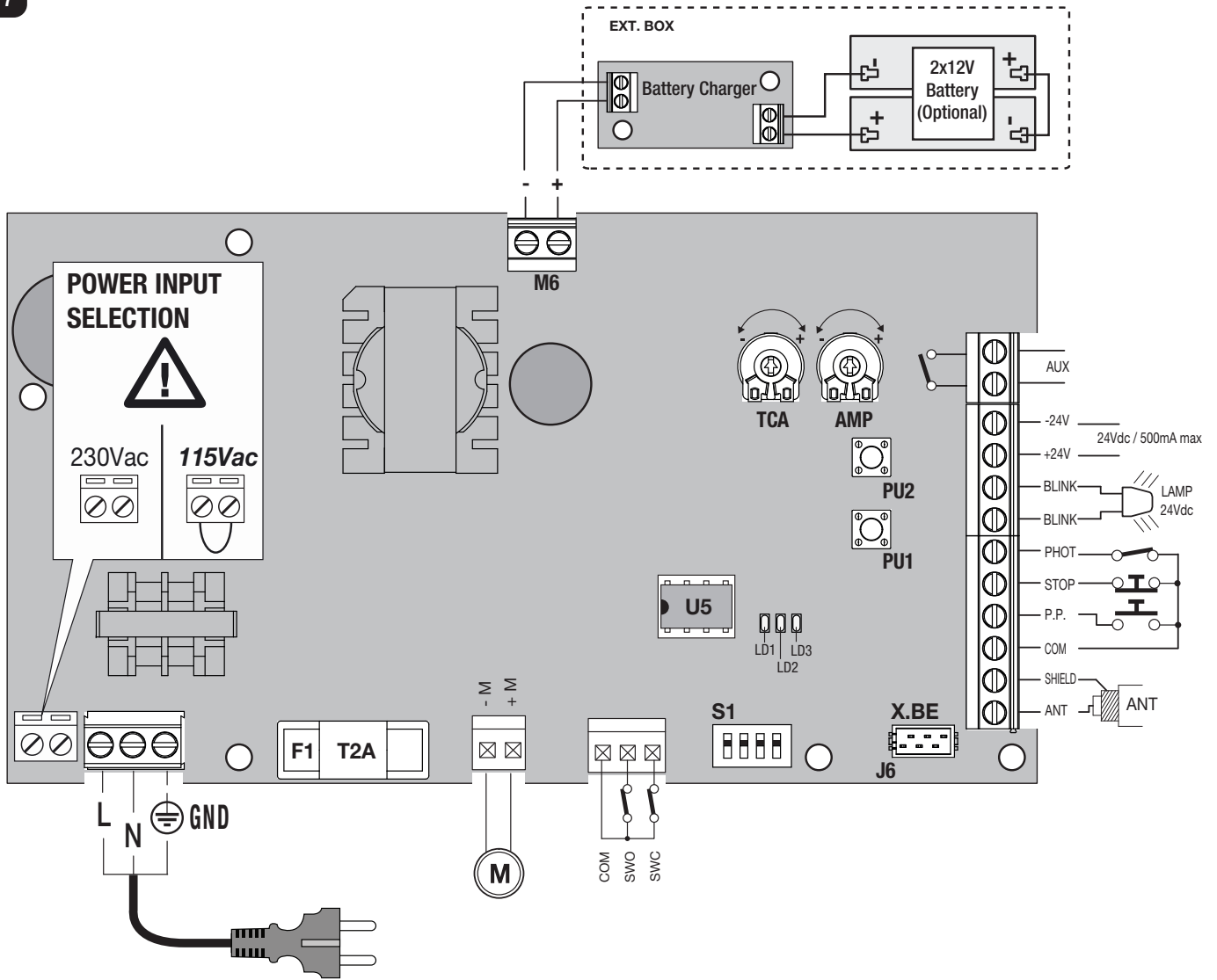

Functions Setup	PU2 PU1 LD1 ON	PU2 PU1 LD2 ON	PU2 PU1 LD3 ON
	PRE [ON/OFF]	AUX [SCA/2°Ch]	REM [ON/OFF]
	Photo Op [ON/OFF]	P.P. [ON/OFF]	STOP [STOP/PED]
	IBL [ON/OFF]	IBCA [ON/OFF]	SCL [ON/OFF]
Speed Setup	Close Speed PU2 PU1 LD3 50/75/100%	Open Speed PU2 PU1 LD1 50/75/100%	
	ESA Setup DIP 4 OFF: ESA OFF	DIP 4 ON: ESA ON	



The product shall not be used for purposes or in ways other than those for which the product is intended for and as described in this manual. Incorrect uses can damage the product and cause injuries and damages.
 The company shall not be deemed responsible for the non-compliance with a good manufacture technique of gates as well as for any deformation, which might occur during use.
 Keep this manual for further use.



This manual has been especially written to be use by qualified fitters.
 Installation must be carried out by qualified personnel (professional installer, according to EN 12635), in compliance with Good Practice and current code.
 Make sure that the structure of the gate is suitable for automation.
 The installer must supply all information on the automatic, manual and emergency operation of the automatic system and supply the end user with instructions for use.



Packaging must be kept out of reach of children, as it can be hazardous.
 For disposal, packaging must be divided the various types of waste (e.g. carton board, polystyrene) in compliance with regulations in force. Do not allow children to play with the fixed control devices of the product.
 Keep the remote controls out of reach of children.
 This product is not to be used by persons (including children) with reduced physical, sensory or mental capacity, or who are unfamiliar with such equipment, unless under the supervision of or following training by persons responsible for their safety.
 Apply all safety devices (photocells, safety edges, etc.) required to keep the area free of impact, crushing, dragging and shearing hazard. Bear in mind the standards and directives in force, Good Practice criteria, intended use, the installation environment, the operating logic of the system and forces generated by the automated system.
 Installation must be carried out using safety devices and controls that meet standards EN 12978 and EN 12453.
 Only use original accessories and spare parts, use of non-original spare parts will cause the warranty planned to cover the products to become null and void.
 All the mechanical and electrical parts composing automation must meet the requirements of the standards in force and outlined by CE marking.



An omnipolar switch/section switch with remote contact opening equal to, or higher than 3mm must be provided on the power supply mains. Make sure that before wiring an adequate differential switch and an overcurrent protection is provided.
 Pursuant to safety regulations in force, some types of installation require that the gate connection be earthed.
 During installation, maintenance and repair, cut off power supply before accessing to live parts.
 Also disconnect buffer batteries, if any are connected.
 The electrical installation and the operating logic must comply with the regulations in force.
 The leads fed with different voltages must be physically separate, or they must be suitably insulated with additional insulation of at least 1 mm. The leads must be secured with an additional fixture near the terminals.
 During installation, maintenance and repair, interrupt the power supply before opening the lid to access the electrical parts
 Check all the connections again before switching on the power.
 The unused N.C. inputs must be bridged.



WASTE DISPOSAL
 As indicated by the symbol shown, it is forbidden to dispose this product as normal urban waste as some parts might be harmful for environment and human health, if they are disposed of incorrectly.
 Therefore, the device should be disposed in special collection platforms or given back to the reseller if a new and similar device is purchased.
 An incorrect disposal of the device will result in fines applied to the user, as provided for by regulations in force.

Descriptions and figures in this manual are not binding. While leaving the essential characteristics of the product unchanged, the manufacturer reserves the right to modify the same under the technical, design or commercial point of view without necessarily update this manual.

1) SPECIFICATIONS

	BULL 424 SW
Power supply	230Vac 50Hz
Power supply, motor	24Vdc
Current drawn	0,4 A
Torque	12 Nm
Work jogging	(intensive use)
Protection level	IP44
Insulation Class	F
Operating temperature	-20°C / +50°C
Gate max. weight	400kg
Rack module	M4
Opening speed	11 m/min
Noise	<70 dB
Lubrication	CASTROL OPTITEMP LP2
Weight	10,2 kg

2) GENERAL INFORMATION

Automatic system, with 24 VDC single-phase power supply for sliding gates, for gates with maximum weight equal to 400kg
BULL is a monobloc system featuring a refined design and reduced dimensions. The motor and an irreversible reduction system, manufactured with high resistant materials, are housed in an aluminium container. BULL is equipped with spring limit switches. The customised key emergency release allows to open and close the gate in case of power failure.

Anti-crash safety is ensured by an electronic device (encoder and amperometric sensor) which detects any obstacle present.

3) PRELIMINARY CHECKS

For a good operation of the automatic system for sliding gates, the gate or door shall meet the following features:

- the track and relevant wheels must feature correct sizes and must undergo adequate maintenance (in order to avert excessive friction during the sliding of the gate).
- during operation, the door shall not excessively oscillate.
- a mechanical stopper (according to regulations in force) shall limit the opening and closing movements.

4) INSTALLATION (fig.1)

Overall dimensions of the gear motor expressed in mm.

5) POSITIONING OF THE FOUNDATION PLATE (FIG.2-3-4-5)

It is very important to keep to dimension X shown in Fig.2. This value depends on the type of rack used:

X = 52 mm for rack in nylon

X = 49 mm for rack in iron, 12x30mm

Preset a corrugated tube (Fig.2 -A) for the passage of power supply cables and connection wires for the accessories.

Check that, at the end of the fitting, the foundation plate is perfectly parallel with respect to the wing.

Fit the system with screw anchors on the bottom of the cement (Fig.3).

Drill 4 holes, diam.10mm, by using the foundation plate as drilling template.

Tightly anchor the foundation plate to ground through the 4 "T" steel screw anchors and the 4 "B" threaded bars, M8x150mm and corresponding "D" nuts and "R" washers.

Alternative fitting systems are available on the market, e.g. anchoring with retaining expansion band (Fig.3 -T2) to be inserted in the hole with some hammer strokes.

Fitting to be cemented (Fig.4)

In this case, after providing an adequate foundation hole, bend the threaded bars as shown in Fig.4.

Submerge the bars in cement, paying attention to the level of the plate.

Wait that the cement hardens.

Fig. 5 shows the completed fitting plate.

Regardless of the type of fitting, check that the threaded bars are firmly anchored to ground and that they protrude for at least 24mm (44 mm for raised installation).

6) FITTING OF THE RACK (fig.6-7-8)

Rack in nylon (Fig.6).

Position the rack at a height of 68 mm from the centre line of the fixing slot provided on the base on which the foundation plate will be fitted. At that height, drill a hole on the gate and provide for a M6 threading.

Keep to the P tooth pitch, even from a section of rack and another. To this purpose, it could be useful to join another section of rack (Part. C)

Rack in Fe 12x30mm (Fig.7).

Position the spacers D by welding them or fitting them with screws to the gate, at 103 mm height from the centre line of the fixing slot provided on the base on which the foundation plate will be fitted. Fix the rack by following points 4.3 and 4.4.

Keep to the P tooth pitch, for all sections of the rack. To this purpose, it could be useful to connect another section of rack (Part. C)

Then fix the rack with V screws, taking care, once the actuator is installed, that 1-mm backlash is left between the rack and the tow wheel (see Fig.8). To this purpose, use the slots on the rack.

7) POSITIONING AND ANCHORING OF THE ACTUATOR (fig.9-10)

Position the gear motor on the foundation plate with the gear centred with respect to the rack.

Release the automatic system and check that the gear be correctly positioned along the entire stroke of the rack. If required, adjust the alignment by using the special slots.

Fix the gear motor to the base by firmly tightening the 4 nuts D and inserting the R.

Apply the two screw covers C.

If the rack is already installed in a position which is higher than the pinion, the plate can be raised (20 mm maximum) by moving the nuts and the washers under the plate, as shown in Fig.10.

If the connecting cables already present make it difficult to fix the standard plate, the optional plate BULL P3 (Fig. 11) can be used, thus allowing to raise the actuator installation by about 34 mm and facilitating the passage of cables.

8) POSITIONING OF THE LIMIT SWITCH BRACKETS (fig.12)

Manually open the gate and leave a clearance from 1 to 3cm according to the weight of the gate between the main door and the mechanical stopper A. Fix the bracket to the limit switch S by using the grains G, so that the limit switch microswitch F is pressed. The same operation should be repeated with gate in the closing phase.

N.B.: The limit switch bracket should be positioned so that the gate can be stopped without hitting the mechanical stopper.

9) MANUAL OPERATION (fig.13)

Should a power failure or malfunction occurs, to manually operate the gate proceed as follows:

- After inserting the customised key C, turn it anti-clockwise and pull the lever L.
- The gear motor is unlocked and the gate can be moved by hand.
- To return to the normal operating mode, close the lever L again and manually activate the gate until it is geared.**5.4)**

10) HOW TO INSTALL THE MAGNETS (BULL424 SW.S - fig.14)

The magnets are housed in special supports (fig.14-"A"). These magnets are to be fitted to the limit switch brackets or the rack and cause the triggering of sensors when they approach them.

Fitting onto the limit switch brackets

The bases are complete with hooking tongue allowing the fitting of the magnets to the limit switch bracket supplied with the operator, as shown in Fig.14-B. This type of fitting allows to rapidly adjust the position of magnets. After calculating the correct distance, fix the support in the correct position by means of a screw, so as to avert the moving of the bracket.

Fitting onto the rack

As an alternative, the supports can be fitted directly to the rack, by using the slots shown in Fig. 14-C. This fitting mode does not allow for subsequent regulations. It is therefore advised to make some trials with temporarily fitted supports before carrying out the final fitting.

IMPORTANT: The correct distance of the magnet with respect to the sensor depends on the installation characteristics. This space cannot be preset and must be adjusted on a trial basis.

The distances regarding the triggering of the sensor (value X) with respect to distance K of 3 and 35 mm, which are shown in Fig. 14 are only indicative. In any case, distance K must not exceed 35 mm as a higher distance will not allow the triggering of the magnetic sensor.

11) BUFFER BATTERIES (fig.15)

An optional kit of buffer batteries is available. This permits the operation of the system also in case of power failure.

The batteries can be installed inside the gear motor as shown in Fig.15.

The support of the control unit has a hole "Fig.15 ref. "A" which facilitates passage of the battery cables.

For further information, please see instructions supplied with the product.

12) WIRE DIAGRAM (fig.16)

For the wire connections of the system and to adjust the operating modes, please refer to the Instruction Manual of the control unit.

In particular, the anti-crash device (encoder) should be adjusted according to regulations in force.

Please remember that the device should be earthed by means of the appropriate terminal.

Fig.16 shows wiring for a standard installation. Before proceeding to wiring, check that the type of cables used is consistent with those required for accessories.

Dimension H stands for the installation height of photocells. A clearance between 40 and 60 cm is advisable.

Key of components:

- 1 Gear motor with incorporated BULL control unit
- 2 M4 rack, Nylon/Fe
- 3 Limit switch brackets
- 4 Photocells
- 5 Mechanical stoppers
- 6 Key selector or digital keyboard
- 7 Flashing light
- 8 Antenna

13) CONTROL UNIT CP.B24-SW ELECTRICAL CONNECTIONS

The following table shows the electrical connections in Fig. 17:

Terminals	Function	Description
SEL 115/230	Mains power supply selection	230 Vac 50/60 Hz (from 207 to 253 Vac) jumper M7 OPEN 115 Vac 50/60 Hz (from 102 to 125 Vac) jumper M7 CLOSED
L/N/GND	Power supply	Mains power supply input 115Vac/230Vac selectable via M7 jumper
MOT	Motor	Quick connector for the connection of 24 Vdc motor
COM/SWO/SWC	Adjustable	Quick connector for the connection of the limit switches COM: Common - SWO Limit Switch Opens (N.C. contact) - SWC Limit switch closes (N.C. contact)
ANT/SHIELD	Antenna	Built-in radio receiver antenna connection ANT: Signal / SHIELD: Display
COM	General	Common for all control inputs.
S.S.	Step-by-Step	Step-by-step key input (N.O. contact). The control unit executes a command at each S.S. impulse according to the sequence: OPENS>STOP>CLOSES>STOP>OPENS or OPENS>CLOSES>OPENS. See dip switch 2
STOP	STOP	STOP key input (N.C. contact) Settable as a PED key (N.O. contact) see dip switch 2
PHOT	Photocell	Photocell input (N.C. contact) active in the closure and opening phase according to the setting of dip switch 2
BLINK	Flashing	24Vdc flashing connection 15W max.
+ 24V -	24 Vac/dc	Power supply output accessories 24Vdc/500mA max.
AUX	Auxiliaries output	Clean contact (N.O.) configurable using Dip Switch 1 as SCA (gate open indicator light) or second radio channel.
J6	X.BE	Quick connector for KNX interface card (item X.BE - See paragraph KNX)
M6	Battery charger	Quick connector for optional battery charger card connection.

14) ARC TRANSMITTERS

IMPORTANT, PLEASE READ CAREFULLY:

The radio receiver in this product is compatible only with ARC (Advanced Rolling Code) transmitters which, thanks to 128 bit coding, guarantee superior anti-copying security.

15) AUTOSET

CAUTION! The autoset procedure described below is mandatory!

During the AUTOSET phase, the control unit performs a number of opening and closing movements during which essential operating parameters are set, including:

- Start- and end-of-run positions.

- Start of the slowing phases.

- Torque values applied during panel movement.

- Recognition of the device connected to the PHOT input.

Procedure:

- 1) Position the leaf in the CLOSURE position (check activation of the SWC limit switch)
- 2) With the control unit connected to the mains, press and hold down the PU1 + PU2 keys until the 3 red LEDs light up cyclically.
- 3) The AUTOSET procedure starts, some opening and closing movements are commanded.
- 4) At the end of the procedure the panel stops in the open position and the LED lights remain steady for 5s to confirm AUTOSET correctly carried out.

16) CHANGES TO SLOWING SPACES

During the AUTOSET phase, a deceleration space can be set higher than the default space set by the control unit. Proceed as follows:

- 1) Bring the leaf in the CLOSURE position (check activation of the SWC limit switch)
- 2) Start-up an AUTOSET procedure: press and hold down the PU1 + PU2 keys until the 3 red LEDs light up cyclically.
- 3) The door will start opening.
- 4) A CLOSING movement will then start at normal speed, during which the slowing starting point can be selected using an S.S. command. (transmitter, S.S. input, PU1) keys when needed.
- 5) An OPENING movement will then start at normal speed, during which the slowing starting point can be selected using an S.S. command. (transmitter, S.S. input, PU1) keys when needed.
- 6) At the end of the procedure the panel stops in the open position and the LED lights remain steady for 5s to confirm AUTOSET correctly carried out.

Disabling the slowing phases

If you do not want the slowing phases, proceed as follows:

- 1) Bring the leaf in the CLOSURE position (check activation of the SWC limit switch)
- 2) Set DIP 1/2/3 ON
- 3) Start-up an AUTOSET procedure: press and hold down the PU1 + PU2 keys until the 3 red LEDs light up cyclically.
- 4) The AUTOSET procedure starts, some opening and closing movements are commanded
- 5) On completion of the autoset manoeuvres, bring the DIP OFF, slowing is now disabled.

17) TRIMMER FUNCTION

TCA Trimmer

Allows to adjust automatic closing time. Adjustment may vary from a minimum of 3s to a maximum of 180s.

With the TCA trimmer turned completely clockwise the TCA is disabled.

With TCA active and the panel open, the LD1 LED starts flashing quickly to indicate the counting of the TCA time in progress.

AMP Trimmer

Adjustment of the sensitivity of the amperometric sensor for obstacle detection during opening and closing.

Rotate the trimmer clockwise (+) to increase the torque, turn counter-clockwise (-) to decrease the torque.

In the case of obstacle detection:

- Stops movement during opening.

- Stops and reopens the panel for about 3s during closing .

CAUTION:

The AMP trimmer increases or decreases the value that the control unit has set in the various points of the run during AUTOSET phase.

It should therefore be set **only after a complete AUTOSET procedure** and in compliance with the regulations in force.

18) DIP-SWITCH FUNCTION (S1)

DIP 1

DIP 1 enables to:

- Enable/disable pre-flashing PRE

- Selection of the AUX output operating mode.

- Enable/disable remote transmitter acquisition REM

The procedure involves switching DIP 1 ON, carrying out the operations described, then switching it back to OFF to confirm programming.

PRE-FLASHING enabling/disabling (PRE)

Switching DIP1 ON with the PU2 key will enable or disable pre-flashing.

The LD1 LED indicates the status of the function:

LED LD1 on: Pre-flashing enabled. The flashing light activates 3s before the motor starts.

LED LD1 off: Pre-flashing disabled (default)

ATTENTION: Switch DIP 1 to OFF at the end of programming.

Selection of the AUX output operating mode

After bringing DIP1 On with key PU1, select the operating mode of the AUX output as SCA (Gate Open Indicator Light) or as Second Radio Channel.

The LD2 LED indicates the status of the function:

LED LD2 on: Second Radio Channel, the output is controlled by the second radio channel of the incorporated receiver (see radio menu).

LED LD2 off: Gate Open Indicator Light, the contact is open with the door closed, intermittent with the door in motion, closed with the door open (default)

ATTENTION: Switch DIP 1 to OFF at the end of programming.

Enabling/disabling of remote transmitter acquisition (REM)

Switching DIP1 to On by simultaneously pressing PU1 + PU2 enables or disables remote acquisition, as described in the paragraph "Remote acquisition of transmitters".

Please note: Reception of duplicate "AK" series transmitters is simultaneously enabled or disabled.

The LD3 LED indicates the status of the function:

LED LD3 on: Remote acquisition enabled (default)

LED LD3 off: Remote learning disabled

ATTENTION: Switch DIP 1 to OFF at the end of programming.

DIP 2

DIP 2 enables:

- Selection of the PHOTO input operating mode.
- Selection of the operating mode of the "S.S. key" and the transmitter. (S.S.)
- Enable the STOP input as the Pedestrian input (Partial opening) (STOP/PED)

The procedure involves switching DIP 2 ON, carrying out the operations described, then switching it back to OFF to confirm programming.

Selection of the PHOTO input mode

After switching DIP2 On with the PU2 key, the PHOTO input operating mode is set.

The LD2 LED indicates the status of the function:

LED LD2 on: PHOTO input enabled both in closure and opening.

In the opening phase: opening of the contact caused by stoppage of the motor, when the photocell is free, opening restarts.
In the closure phase: opening of the contact causes stoppage of the motor, when the photocell is free, the running direction inverts (opens).

LED LD2 off: PHOTO input enabled only in closure (default).

In the closure phase: opening of the contact causes stoppage of the motor and inversion of the running direction (opens).

ATTENTION: Switch DIP 2 to OFF at the end of programming.

Selection of the operating mode of the "SS key"

After switching DIP2 On with the PU1 key, the SS key and transmitter operating mode is set.

The LD2 LED indicates the status of the function:

LED LD2 on: OPENS>CLOSES>OPENS> operation

LED LD2 off: OPENS>STOP>CLOSES>STOP> (default) operation.

ATTENTION: Switch DIP 2 to OFF at the end of programming.

STOP input enabled/disabled as PEDESTRIAN INPUT

After switching DIP2 On, simultaneously pressing PU1+ PU2, the STOP input is enabled or disabled as the input for the PEDESTRIAN command (becoming a N.O. input)

The LD3 LED indicates the status of the function:

LED LD3 on: STOP input enabled as the PEDESTRIAN input (N.O.).

LED LD3 off: No change to the STOP input (default).

ATTENTION: Switch DIP 2 to OFF at the end of programming.

DIP 3

DIP 3 enables:

- Enable/disable the apartment complex function (IBL)
- Enable/disable the impulses block function in the TCA phase (IBCA)
- Enable/disable the rapid closure function (SCL)

The procedure involves switching DIP3 to ON, carrying out the operations described, then switching it back to OFF to confirm programming.

APARTMENT BLOCK FUNCTION (IBL) enabling/disabling

After switching DIP3 On with the PU2 key, the apartment complex function is enabled or disabled (The S.S. or transmitter impulse has no effect during the opening phase)

The LD1 LED indicates the status of the function:

LED LD1 on: Apartment complex function enabled.

LED LD1 off: Sharing function disabled (default).

ATTENTION: Switch DIP 3 to OFF at the end of programming.

Enable the impulses block function in the TCA phase (IBCA)

After switching DIP3 On with the PU1 key, the IBCA function is enabled or disabled (The S.S. or transmitter impulse has no effect during the TCA pause)

The LD2 LED indicates the status of the function:

LED LD2 on: IBCA function enabled.

LED LD2 off: IBCA function disabled (default).

ATTENTION: Switch DIP 3 to OFF at the end of programming.

RAPID CLOSURE (SCL) enabling/disabling

After switching DIP3 On, simultaneously pressing PU1+ PU2 enables or disables rapid closure (with the gate open or in motion, intervention of the photocell causes automatic closure after 3s. Active only with TCA enabled)

The LD3 LED indicates the status of the function:

LED LD3 on: Rapid closure enabled.

LED LD3 off: Rapid closure disabled (default).

ATTENTION: Switch DIP 3 to OFF at the end of programming.

DIP 4

Disabling of the ESA energy saving function.

With the ESA function enabled once opening or closing movements have been completed, the control unit is in maximum energy efficiency condition, reducing absorption to minimum and disconnecting accessory outputs.

On: ESA energy saving function enabled (default).

To use if you want to have the accessories power supply output always enabled, for example if using 24 Vdc keypads or other devices that need to be always powered

Off: ESA energy saving function disabled.

19) OPENING AND CLOSING MOVEMENT SPEED ADJUSTMENT

You can adjust the opening and closing movement speed following this procedure (the slowing speed remains unchanged):

Switch DIP 1 and DIP 2 ON.

with the PU1 key, select the CLOSURE speed, indicated by LED LD3

LD3 1 flashing	50% of maximum speed (Default)
LD3 2 flashes	75% of maximum speed
LD3 steady light	maximum speed

with the PU2 key, select the OPENING speed, indicated by LED LD1

LD1 1 flashing	50% of maximum speed
LD1 2 flashes	75% of maximum speed
LD1 steady light	maximum speed (Default)

ATTENTION: Switch DIP 1 and 2 OFF at the end of programming.

There is a label applied inside the central cover with the table in Fig. 18 which schematically summarises the functions described above.

20) OPERATOR PRESENT MODE

Switching DIP to ON changes the control unit to OPERATOR PRESENT mode.

The PHOT input takes on the CLOSE key function (connect key with N.O. contact).

The S.S. input takes on the OPEN key function (connect key with N.O. contact).

The OPEN/CLOSE keys must remain pressed during the movement.

Opening the STOP input stops the motor. Simultaneous pressing of OPEN/CLOSE keys stops the motor.

21) CONFIGURATION OF BUILT-IN RECEIVER (MANUAL STORAGE)

The control unit is equipped with a built-in radio module to receive ARC rolling-code remote controls, with a frequency of 433.92MHz.

Before using the remote control, please study the information with care, the storage procedure is shown as follows, the device is able to store up to 64 different codes.

Storage of a transmitter key with S.S. activation

- Press the PU2 key once for 1s, the LD1 LED emits 1 flash with 1s pause.
- Press the key of the transmitter to be memorised with S.S. function within 10s, the 3 red LEDs light up for 1s, then, after storing, the receiver automatically exits the programming phase.

Storage of a transmitter key with SECOND RADIO CHANNEL function enabling.

- Press the PU2 key once for 1s, the LD1 LED emits 1 flash with 1s pause.
- Press the PU2 key again, the LD1 LED flashes twice with 1s pause
- Press the key of the transmitter to be memorised the 2nd Radio Channel within 10s, the 3 red LEDs light up for 1s, then, after storing, the receiver automatically exits the programming phase.

The output enables for 1 second on each press of the memorised key.

To exit programming without storing the transmitter, wait 10s.

Storage of a transmitter key with PEDESTRIAN function enabling

- Press the PU2 key once for 1s, the LD1 LED emits 1 flash with 1s pause.
- Press the PU2 key twice more, the LD1 LED will flash 3 times with 1s pause
- Press the key of the transmitter to be memorised with the Pedestrian function within 10s, the 3 red LEDs light up for 1s, then, after storing, the receiver automatically exits the programming phase.

Pressing the key associated with the pedestrian function controls partial opening of the leaf (approx. 1.5m)

Deletion of a radio code

- Press the PU2 key once for 1s, the LD1 LED emits 1 flash with 1s pause.
- Press the PU2 key again 3 times, the LD1 LED will flash 4 times with 1s pause
- Press the key of the transmitter you want to delete within 10s, the 3 red LEDs light up for 1s, then, after deletion the receiver automatically exits the programming phase.

Remote acquisition of a transmitter

If you already have a memorised transmitter, others can be memorised without accessing the control panel. Remote storage must be performed with the panel completely open, regardless of the TCA setting. Proceed as follows:

- 1 Press the hidden key on the previously memorised transmitter.
- 2 Press the key of the memorised transmitter to be copied within 10s. The flashing light switches on to conform receipt.
- 3 Press the hidden key of the new transmitter to which the function is to be associated within 10s.
- 4 Press the key of the new transmitter to which you want to associate the function selected in point 2 within 10s. The flashing light switches on to conform receipt.
- 5 The new transmitter has been memorised, the receiver exits the programming phase.

E.g.: key 1 of TX "A" contains the S.S. function that you want to assign to key 2 of the new TX "B"; press in sequence:

hidden key of TX A >> key 1 of TX A >> hidden key of TX B >> key 2 of TX B.

Deleting all transmitters from memory

- Keep the PU2 key pressed for 15s, the LD1 / 2/3 LEDs and the service light start flashing quickly and turn off when cancellation is complete.
- Release the PU2 key, the memory has been erased.

PLEASE NOTE: Transmitters may not be memorised during the opening/closing phases of the motor due to safety reasons.

22) KNX COMMUNICATION INTERFACE

Today, KNX is the open global standard, compliant with the main European and international standards, allowing the automated and decentralized management of technological systems of a wide range of structures: commercial buildings, industries, offices, homes, public premises, schools and many more.

This product is compatible with KNX standard and can be connected to a KNX network using the optional X.BE accessory.

For further information, please refer to the instructions supplied with the X.BE.

23) TOTAL RESET

This procedure takes the control panel back to factory default conditions.

ATTENTION: All memorised transmitters are also deleted.

Total reset procedure:

- Disconnect from the mains
- Press and hold PU1 + PU2 keys
- Connect to the mains
- Wait for LD1 / LD2 / LD3 LEDs to turn on in sequence, total reset is now complete.

24) LED DIAGNOSTICS

LEDs LD1/LD2/LD3 in normal operation give a number of indications:

LD1

Slow flashing: Mains supply present, no input active

Fast flashing: TCA pause count

LD2

on: motor at end-of-run CLOSING

LD3

on: motor at end-of-run OPENING

LD1+LD2+LD3

1 flash with pause: Inputs error Check connections SS/PHOT/STOP

2 flashes with pause*: Motor/safety error Check connection of the motor and the safety devices (photocells, stop)

3 flashes with pause: Amperometric sensor intervention

* If testing of the safety devices is unsuccessful, no manoeuvre is controlled and flashing switches on for 10s.

LD2+LD3

fast flashing thermal protection intervention

NORME DI SICUREZZA

- Non sostare nella zona di movimento dell'anta.
- Non lasciare che i bambini giochino con i comandi o in prossimità dell'anta.
- In caso di anomalie di funzionamento non tentare di riparare il guasto ma avvertire un tecnico specializzato.

MANOVRA MANUALE E D'EMERGENZA

In caso di mancanza dell'energia elettrica o di guasto, per azionare manualmente l'anta procedere come segue:

- Inserita la chiave personalizzata C, farla ruotare in senso antiorario e tirare la leva L.
- Il motoriduttore è così sbloccato ed è possibile movimentare manualmente l'anta.
- Per ristabilire il normale funzionamento richiudere la leva L ed azionare il cancello manualmente fino ad ingranamento avvenuto.

MANUTENZIONE

- Controllare periodicamente l'efficienza dello sblocco manuale di emergenza.
- Astenersi assolutamente dal tentativo di effettuare riparazioni, potreste incorrere in incidenti; per queste operazioni contattare un tecnico specializzato.
- L'attuatore non richiede manutenzioni ordinarie, tuttavia è necessario verificare periodicamente l'efficienza dei dispositivi di sicurezza e le altre parti dell'impianto che potrebbero creare pericoli in seguito ad usura.

SMALTIMENTO



Come indicato dal simbolo a lato, è vietato gettare questo prodotto nei rifiuti domestici in quanto alcune parti che lo compongono potrebbero risultare nocive per l'ambiente e la salute umana, se smaltite scorrettamente. L'apparecchiatura, pertanto, dovrà essere consegnata in adeguati centri di raccolta differenziata, oppure riconsegnata al rivenditore al momento dell'acquisto di una nuova apparecchiatura equivalente. Lo smaltimento abusivo del prodotto da parte dell'utente comporta l'applicazione delle sanzioni amministrative previste dalla normativa vigente.

SAFETY MEASURES

- Do not stand within the gate movement area.
- Children must not play with controls and near the gate.
- In the event of malfunctions, do not attempt to repair the failure but contact the specialised personnel.

MANUAL AND EMERGENCY MANOEUVRE

In the event of power failure or malfunction, to manually operate the gate proceed as follows:

- After inserting the customized key C, turn it anti-clockwise and pull the lever L.
- The geared motor is unlocked and the gate can be moved by hand.
- To return to the normal operating mode, close the lever L again and manually activate the gate until it is geared.

MAINTENANCE

- Every month check the good operation of the emergency manual release.
- It is mandatory not to carry out extraordinary maintenance or repairs as accidents may be caused. These operations must be carried out by qualified personnel only.
- The operator is maintenance free but it is necessary to check periodically if the safety devices and the other components of the automation system work properly. Wear and tear of some components could cause dangers.

WASTE DISPOSAL



As indicated by the symbol shown, it is forbidden to dispose this product as normal urban waste as some parts might be harmful for environment and human health, if they are disposed of incorrectly. Therefore, the device should be disposed in special collection platforms or given back to the reseller if a new and similar device is purchased. An incorrect disposal of the device will result in fines applied to the user, as provided for by regulations in force.

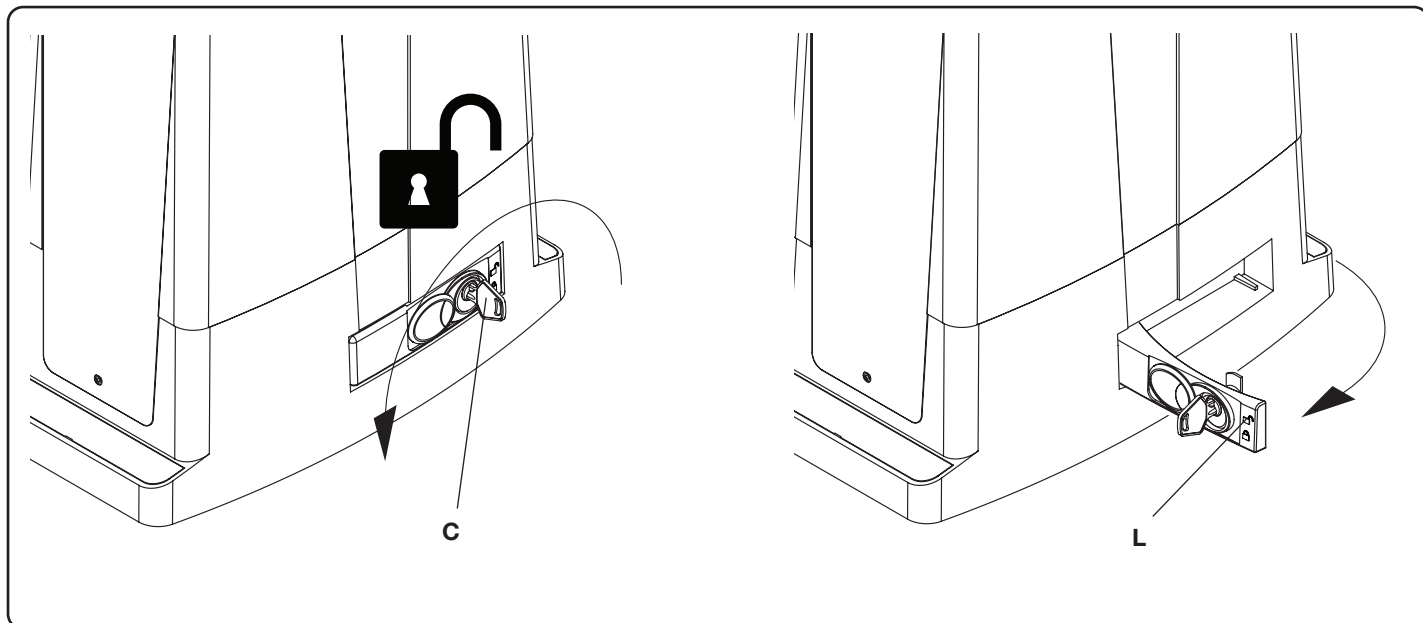

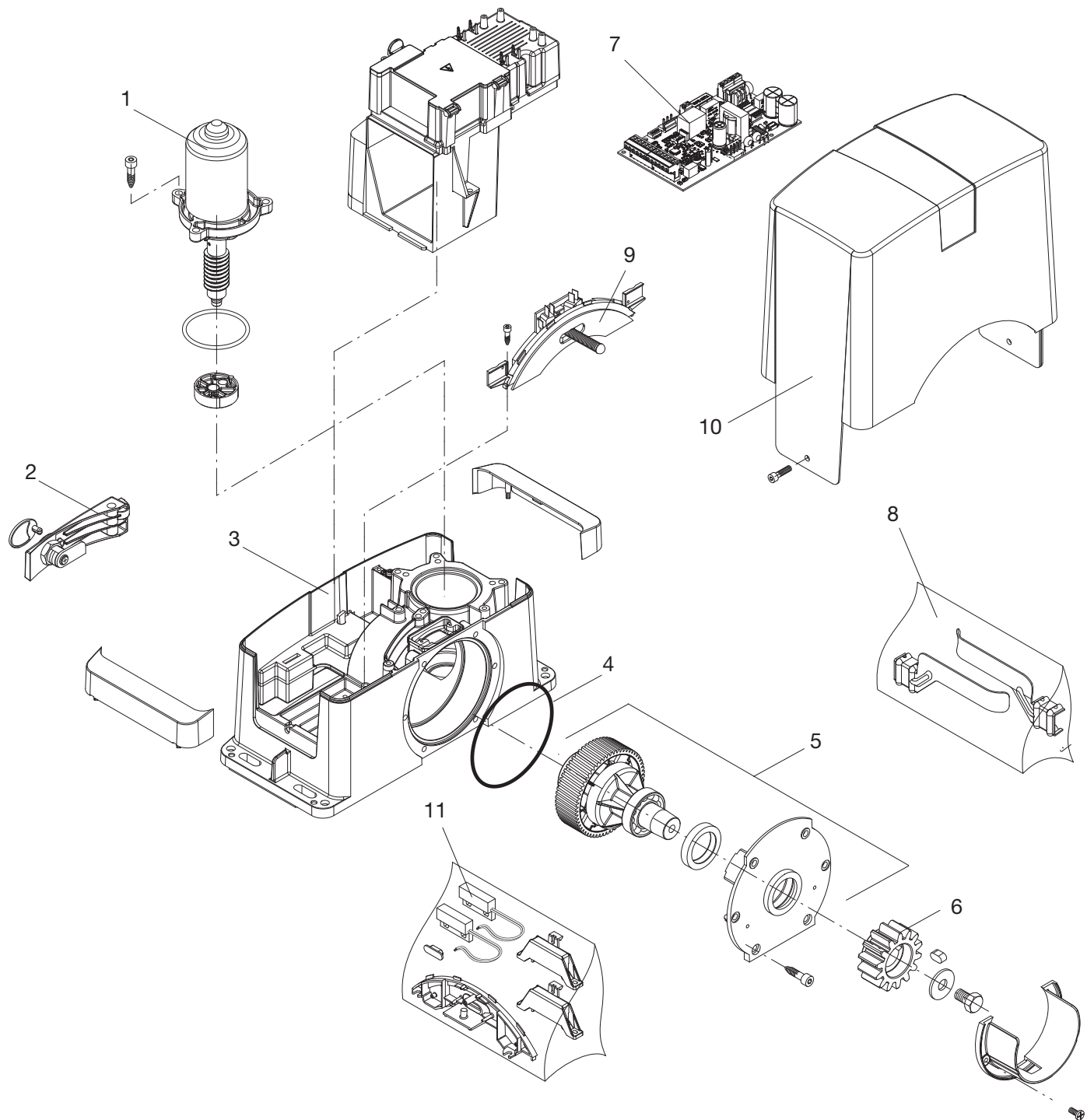

Ref.	BULL 424 SW	Note
1	968601942	
2	968601943	
3	968601944	
4	9686421	
5	968601945	
6	9686414	
7	968601947	
8	9688174	
9	9686329	
10	9686427	
11	9688102	BULL__S

BENINCA

AUTOMATISMI BENINCÀ SpA - Via Capitello, 45 - 36066 Sandrigo (VI) - Tel. 0444 751030 r.a. - Fax 0444 759728
